

DIO82611/2

High Frequency Synchronous Rectifier Controller

Features

- Supports Topologies such as Active Clamp Flyback, QR, DCM, CCM Flyback and LLC
- MOSFET V_{DS} Sensing up to 230 V
- Maximum switching frequency:
 - 800 kHz for DIO82612
 - 1 MHz for DIO82611
- Wide VIN Range: 5~30V
- Gate Driver with 3A Sink and 1A Source
- Adaptive Minimum Off-time for Increased Noise Immunity
- High-side or Low-Side Rectification
- Low start up current: 100 μ A (Typ.)
- Low standby current: 300 μ A (Typ.)
- Turn-off Propagation Delay: 20ns (Typ.)
- 9.5V Drive Clamp for Reduced Driving Loss
- Compact package: TSOT23-6

Applications

- AC-DC Adapters
- USB Type-C and PD AC Adapters
- Server and Telecom Power Supply
- AC-to-DC Auxiliary Power Supply

Typical Application

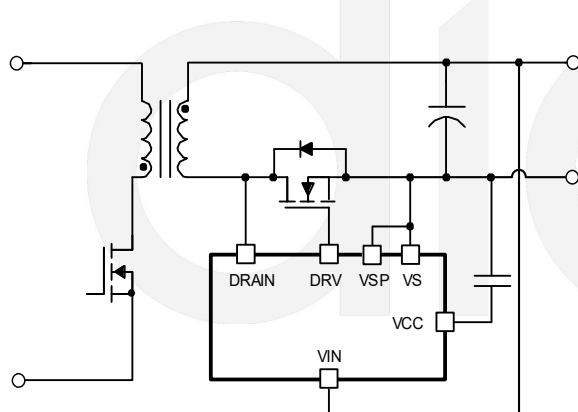

Low-Side SR

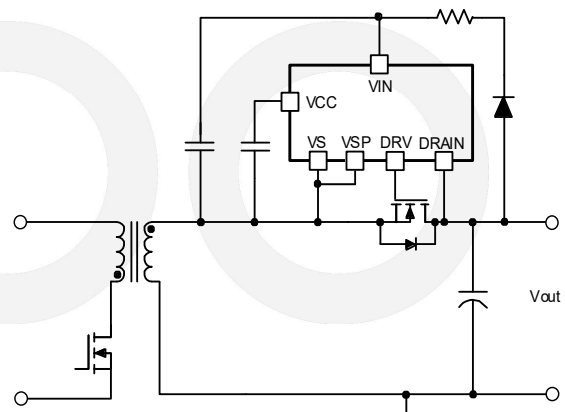

High-Side SR

Descriptions

The DIO82611/2 is a high frequency Synchronous Rectifier controller, specifically designed for standard and logic-level NMOSFET and GaN power devices with minimal external components targeting at high frequency Flyback applications. The drain to source (V_{DS}) sensing control scheme allows DIO82611/2 to work with multiple topologies, such as ACF/QR/DCM/CCM Flyback and LLC, et.

DIO82611/2 offers different minimum on-times to provide additional noise immunity. Robust operation in continuous conduction mode (CCM) is further enhanced with proportional gate-drive. Efficiency and noise immunity is enhanced with adaptive minimum off-time.

DIO82611/2 has multiple features that improve efficiency. The fast comparator with short propagation delays reduces switching loss. The 9.5V drive clamp reduces MOSFET driving losses. Multiple standby modes further decreases standby power. This chip adopts special design to achieve reliable protection for safety requirement.

Ordering Information

Order Part Number	Top Marking		T _A	Package	
DIO82611TST6	H1YW	Green	-40 to 85°C	TSOT23-6	Tape & Reel, 3000
DIO82612TST6	H2YW	Green	-40 to 85°C	TSOT23-6	Tape & Reel, 3000

Pin Assignments

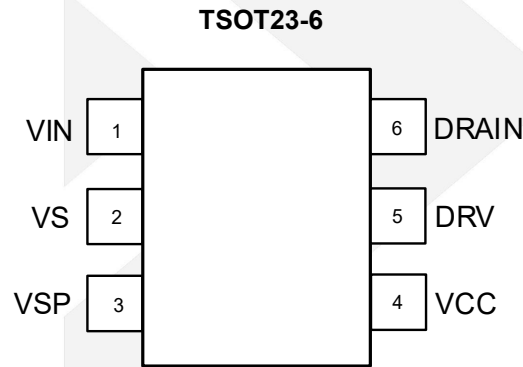

Figure 1. Top View

Pin Description

Pin Name	Description
VCC	Analog input. This pin is both the power supply to internal circuit and the voltage to be monitored.
DRAIN	DRAIN of the MOSFET.
VIN	Power supply pin.
DRV	Gate driver pin.
VS	VS is the internal ground reference of the DIO82611/2.
VSP	Power ground pin



Absolute Maximum Ratings

Stresses beyond those listed under “Absolute Maximum Rating” may cause permanent damage to the device. These are stress ratings only and functional operation of the device at these or any other condition beyond those indicated in the operational sections of the specifications is not implied. Exposure to absolute maximum rating conditions for extended periods may affect device reliability.

Symbol	Parameter	Rating	Unit
Input voltage ⁽¹⁾	VIN	-0.3 to 30	V
	DRAIN	-0.7 to 200	V
	DRAIN for $I_{DRAIN} \leq -10$ mA	-1.0 to 200	V
	DRV	-0.3 to V_{CC}	V
	VCC	12	V
Output current, peak	DRV pulsed, $t_{PULSE} \leq 4$ ms, duty cycle $\leq 1\%$	± 3	A
$R_{\theta JA}$	Junction-to-ambient thermal resistance	200	$^{\circ}C/W$
$R_{\theta JC}$	Junction-to-case thermal resistance	100	$^{\circ}C/W$
T_J	Junction temperature range	-40 to 125	$^{\circ}C$
T_{STG}	Storage temperature range	-65 to 150	$^{\circ}C$

(1) Input voltages more negative than indicated may exist on any listed pin without excess stress or damage to the device if the pin's input current magnitude is limited to less than -10mA.

Recommended Operating Conditions

The Recommended Operating Conditions table defines the conditions for actual device operation. Recommended Operating conditions are specified to ensure optimal performance to the datasheet specifications. DIOO does not Recommend exceeding them or designing to Absolute Maximum Ratings.

Symbol	Parameter	Rating	Unit
VIN	input voltage	4 to 28	V
T_J	Junction temperature	-40 to 125	$^{\circ}C$



DIO82611/2

Electrical Characteristics

At $V_{IN} = 12 V_{DC}$, $C_{DRV} = 0 pF$, $C_{VCC} = 2.2 \mu F$, $-40^{\circ}C \leq T_J = T_A \leq +125^{\circ}C$, all voltages are with respect to V_S , and currents are positive into and negative out of the specified terminal, unless otherwise noted. Typical values are at $T_J = +25^{\circ}C$.

Symbol	Parameter	Test Conditions	MIN	TYP	MAX	UNIT
VIN POWER Section						
I_{VIN_ST}	VIN current, VCC undervoltage	$V_{IN} = 4 V$, DRAIN = 0 V		100	150	μA
I_{VIN_ON}	VIN current, operation state	$V_{IN} = 12 V$		0.92		mA
		$V_{IN} = 5 V$		0.9		mA
I_{VIN_SB}	VIN current, standby mode	$V_{IN} = 12 V$, DRAIN = 1 V		390		μA
		$V_{IN} = 5 V$, DRAIN = 1 V		300		μA
VCC CONTROL Section						
V_{VCC_ON}	VCC turn-on threshold	Turn-on detected by I_{VIN} rising		4.5		V
V_{VCC_OFF}	VCC turn-off threshold	Turn-off detected by I_{VIN} falling		4		V
V_{VCC_HYST}	VCC UVLO hysteresis	$V_{VCC_HYST} = V_{VCC_ON} - V_{VCC_OFF}$		0.5		V
DRAIN SENSING Section						
V_{DRV_ON}	DRAIN threshold voltage when DRV turn on	DRAIN falling, $T_J = 25^{\circ}C$		-240		mV
V_{DRV_OFF}	DRAIN threshold voltage when DRV turn off	DRAIN rising, $-40^{\circ}C \leq T_J \leq 125^{\circ}C$		-10		mV
$t_{d_DRV_ON}$	DRV turn-on propagation delay	DRAIN transitions from 4.7V to -0.4V, $T_J = 25^{\circ}C$		60		ns
$t_{d_DRV_OFF}$	DRV turn-off propagation delay	DRAIN moves from -0.3V to 4.7V in 5ns		20		ns
DRIVER Section						
R_{SOURCE}	DRV pull-up resistance	$I_{DRV} = -20 mA$		6	12	Ω
R_{SINK}	DRV pull-down resistance	$I_{DRV} = 100 mA$		0.7	1.4	Ω
V_{DRV_CLP}	DRV clamp level	$V_{IN} > V_{OUT} + V_{DO(IN-OUT)}$		9.5		V
V_{DRV_L}	DRV output low voltage	$I_{DRV} = 100 mA$, $V_{IN} = 12 V$		60	150	mV
I_{SOURCE}	Gate driver maximum source current			1		A
I_{SINK}	Gate driver maximum sink current			3		A
VCC SUPPLY Section						
V_{VCC}	VCC pin regulation level	$I_{LOAD_VCC} = 0 mA$		9.5		V
V_{VCC_REG}	Load regulation on VCC	$I_{LOAD_VCC} = 0 mA$ to 10 mA			0.1	V
I_{VCC_SHORT}	VCC short-circuit current	$V_{VCC} = 0 V$		5	15	mA
I_{VCC_LMT}	VCC current limit	$V_{VCC} = 8.5 V$		40	60	mA



DIO82611/2

High Frequency Synchronous Rectifier Controller

PWM Section

t_{ON_MIN}	Minimum SR conduction time		360	520	670	ns
t_{OFF_MIN}	Minimum SR off-time		260	380	490	ns
t_{OFF_MAX}	Maximum SR off-blanking time			3.8		μ s

GATE DRIVER Section

t_{RISE_DRV}	DRV rise time	10% to 90%, $C_{DRV} = 4.7$ nF		30		ns
t_{FALL_DRV}	DRV fall time	90% to 10%, $C_{DRV} = 4.7$ nF		15		ns

STANDBY Section

t_{DET_SB}	Standby mode detection time			4.5		ms
f_{TRIG_SB}	Average Frequency entering standby mode			9		kHz
f_{HYS_SB}	Average frequency hysteresis for standby mode		2	3	4	kHz



Function Diagram

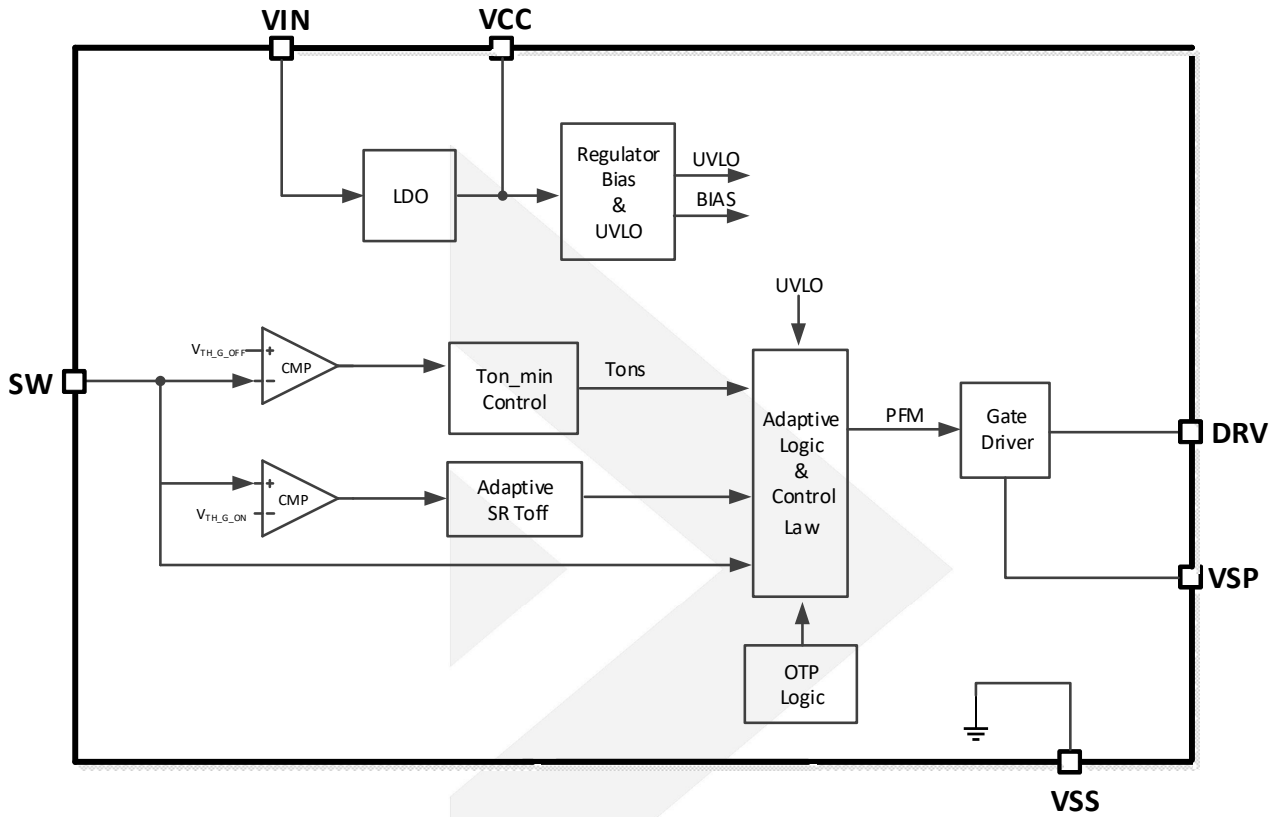

Typical System Application

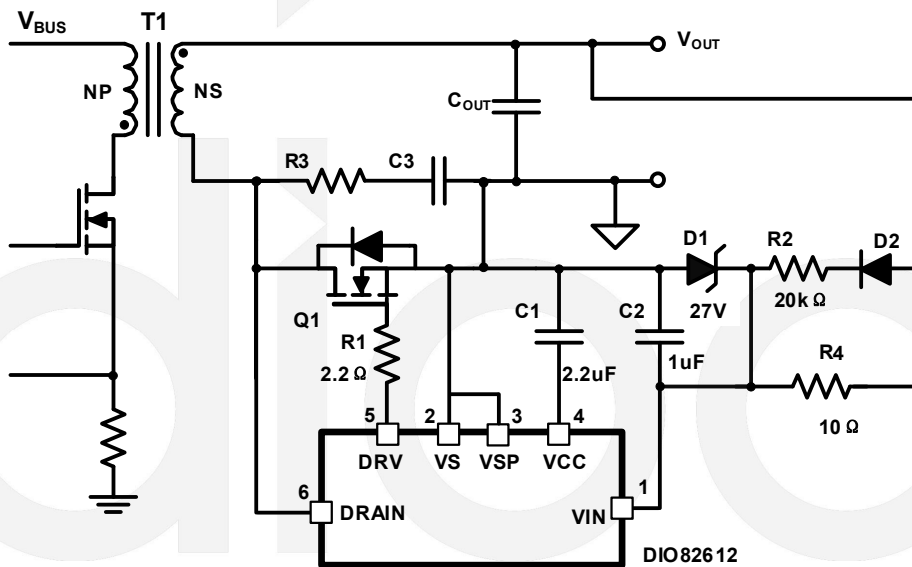

Operation

The DIO82611/2 is an intelligent synchronous rectifier (SR) controller, which uses drain-to-source voltage sensing to drive the SR MOSFET. The SR MOSFET is turned on when V_{DS} exceeds turn-on threshold V_{DRV_ON} , and is turned off when V_{DS} falls below V_{DRV_OFF} . The DIO82611/2 supports operation in DCM/CCM/QR/ACF topology. Fixed minimum on-time allows the controller to operate up to 1MHz switching frequency. The adaptive minimum off-time control simplifies the design, making the controller suitable for a wide range of applications and switching frequencies, with good immunity to noise caused by parasitic ringing. To minimize the standby power, automatic light-load mode disables the DRV pulses when the average switching frequency of the converter becomes lower than 9 kHz. The wide VIN range and gate driver clamp make the controller ideal for wide output voltage range applications such as USB Power Delivery adapters.

Feature Description

Power Management

The DIO82611/2 SR controller is powered from VCC pin through the internal linear regulator between VIN pin and VCC pin. This configuration allows optimal design of the gate driver stage to achieve fast driving speed, low driving loss and higher noise immunity.

In low-side SR configuration, the DIO82611/2 is powered from the output voltage directly.

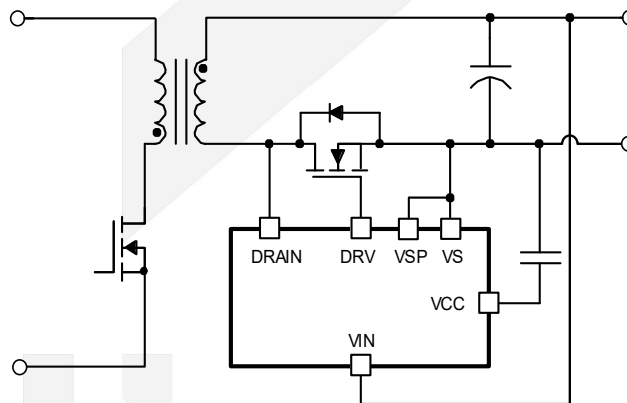

Low-Side SR

During start up, the output voltage rises from zero. With the rising of output voltage, the internal linear regulator operates in a pass-through mode, and the VCC pin voltage rises together with the output voltage. The UVLO function of DIO82611/2 monitors the voltage on the VCC pin instead of the VIN pin. Before VCC pin voltage rises above UVLO on threshold V_{CC_ON} , DIO82611/2 consumes the minimum current I_{VIN_START} . Once the VCC voltage rises above V_{CC_ON} , the device starts to consume the full operating current and controls the switching of the SR MOSFET.

When VIN voltage is above 9.5 V, the internal linear regulator operates in regulator mode. The VCC pin is well regulated at 9.5 V. It is required to have a sufficient bypass capacitor on the VCC pin to ensure stable operation of the linear regulator. A 2.2μF bypass capacitor is recommended.

When VIN voltage is below 9.5 V, the internal linear regulator operates in pass-through mode. Depending on the load current, the regulator has a voltage drop of 200mV. The DIO82611/2 continues to operate during this mode

until the VCC pin voltage drops below V_{CCOFF} .

The same biasing method can also maintain the SR controller operation in high-side SR configuration.

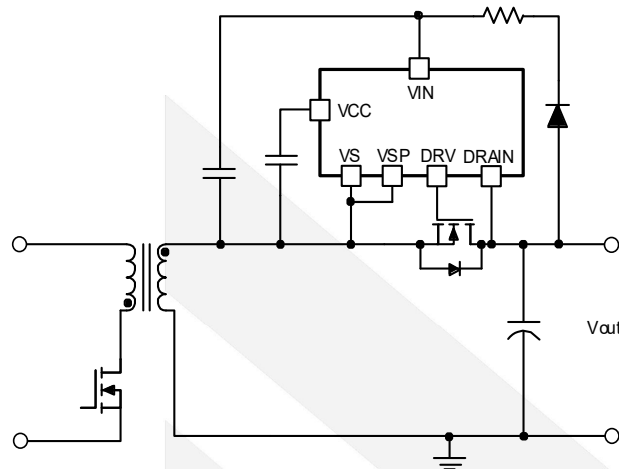

High-Side SR

Synchronous Rectifier Control

The DIO82611/2 SR controller determines the conduction time of the SR-MOSFET by comparing the drain-to-source voltage (V_{DS}) of the MOSFET against a turn-on threshold and a turn-off threshold. The DRV output is driven high when V_{DS} of the MOSFET falls below $V_{THDRVON}$ and is driven low when V_{DS} rises above $V_{THDRVOFF}$. Since when SR is conducting, its voltage V_{DS} is negative, more negative voltage drop means higher SR current.

Adaptive Blanking Time

In power converters, the sensed the voltage across the SR is often noisy which caused by the parasitic ringing. This parasitic ringing is usually associated with the SR and the primary-side switch turning on and off. Blanking time is used to deal with the parasitic ringing to prevent SR false turn on and off.

Gate Voltage Clamping

With the wide VIN voltage range capability, DIO82611/2 clamps the gate driver voltage to a maximum level of 9.5V to allow fast driving speed, low driving loss and compatibility with different MOSFETs. The 9.5V level is chosen to minimize the conduction loss for the non-logic level MOSFETs.

The gate driver voltage clamp is achieved through the regulated VCC pin voltage. When VIN voltage is above 9.5V, the linear regulator regulates the VCC pin voltage to be 9.5 V, which is also the power supply of the gate driver stage. This way, the MOSFET gate is clamped at 9.5 V, regardless of how high the VIN voltage is. When the VIN voltage is close to or below the programmed VCC pin regulation voltage, DIO82611/2 can no longer regulate the VCC pin voltage. Instead, it enters a pass-through mode where the VCC pin voltage follows the VIN pin voltage with slight voltage drop out. During this time, the gate driver voltage is lower than its programmed value but still provides SR driving capability. The DIO82611/2 is disabled once the VCC pin voltage drops below its UVLO level.



DIO82611/2

Standby Mode

With more stringent efficiency standards such as Department of Energy level VI, external power supplies are expected to maintain ultra-low standby power at no-load conditions. So it is essential for the SR controller to enter the low-power standby mode.

During standby mode, the power converter loss allocation is quite different compared to heavy load. At heavier load, both conduction loss and switching loss are quite high. However, at light load, the conduction loss becomes insignificant and switching loss dominates. To help improve standby power, modern power supply controllers often enter burst mode to save switching loss. Furthermore, in each burst switching cycle, the energy delivered is maximized to minimize the number of switching cycles needed and further reduce the switching loss.

Instead, in DIO82611/2, a frequency based standby mode detection is used. DIO82611/2 continuously monitors the average switching frequency of the SR. Once the average switching frequency of the SR controller drops below 9 kHz, the DIO82611/2 enters standby mode and reduces its current consumption to I_{VIN_STBY} . During standby mode, the DRV pin is kept low while the SR switching cycle is continuously monitored. Once the average switching frequency is more than 12 kHz over a 4.5 ms window, the SR operation is enabled again. DIO82611/2 ignores the first six SR switching cycles after coming out of standby mode to make sure the SR isn't turned on in the middle of the switching cycle.

Different operation Modes

UVLO Mode

DIO82611/2 uses the VCC pin voltage to detect UVLO instead of the VIN pin voltage. When the VCC voltage to the device has not yet reached the V_{VCC_ON} threshold, or has fallen below the UVLO threshold V_{VCC_OFF} , the device operates in the low-power UVLO mode. In this mode, most internal functions are disabled and VIN current is I_{VIN_ST} , typically less than 100 μ A. If the VCC pin is above 2V, there is an active pull-down from DRV to VS to prevent SR turn-on due to noise. When the VCC pin voltage is less than 2V, there is a weak pull down from DRV to VS and this also helps prevent false turn on of the SR MOSFET. The device exits UVLO mode when VCC increases above the V_{VCC_ON} threshold.

Standby Mode

Standby mode is a low-power operating mode to help achieve low standby power for the entire power supply. DIO82611/2 detects the operating frequency of the SR MOSFET and enters or exits standby mode operation automatically. VCC current reduces to I_{VIN_SB} level. During standby mode, the majority of the SR control functions are disabled, except the switching frequency monitoring, VCC monitoring and the active pull-down on the gate driver.

Hi Mode

Hi mode is the normal operating mode of the controller when not in UVLO mode or standby mode. In this mode, VCC current is higher because all internal control and timing functions are operating. VCC current is the sum of I_{VIN_ON} plus the average current necessary to drive the load on the DRV output. The DRV voltage is automatically adjusted based on the SR MOSFET drain to source voltage according to the proportional gate drive operation in Hi mode.



DIO82611/2

High Frequency Synchronous Rectifier Controller

CONTACT US

Dioo is a professional design and sales corporation for high-quality and performance analog semiconductors. The company focuses on industry markets, such as, cell phone, handheld products, laptop, and medical equipment and so on. Dioo's product families include analog signal processing and amplifying, LED drivers and charger IC. Go to <http://www.dioo.com> for a complete list of Dioo product families.

For additional product information, or full datasheet, please contact with our Sales Department or Representatives.

dioo