

DIO8280A

High-Efficiency, 16-80V Input, 400kHz Buck CC LED Driver

Features

- Internal 85V Power MOSFET
- Common-anode design for simplified wiring achieve low system cost
- Wide input range: 16-80V
- 400kHz switching frequency
- 200mΩ low $R_{DS(ON)}$ MOSFET for Maximum 2A LED current output
- Support PWM/Analog dimming
- Multiple protection features:
 - ✧ Reliable LED open protection
 - ✧ Reliable LED short protection
 - ✧ Reliable Rcs short protection
 - ✧ Reliable OCP protection
 - ✧ Reliable over thermal protection
- Compact package: EP-SOIC8

Descriptions

The DIO8280A consists of an integrated grounding Buck Regulator and 85V power MOSFET, specifically designed for a high performance non-isolated converter with minimal external components targeting at LED lighting applications.

The DIO8280A drives the Buck converter with ultra-low $R_{DS(ON)}$ power switch to achieve higher efficiency and keeps the Buck converter connecting PWM signal with EN pin or connecting Analog signal with CF pin to achieve dimming control.

Applications

- T-tube LED lighting
- Dimming lighting
- Stage Lamp
- Landscape lighting

Function Block

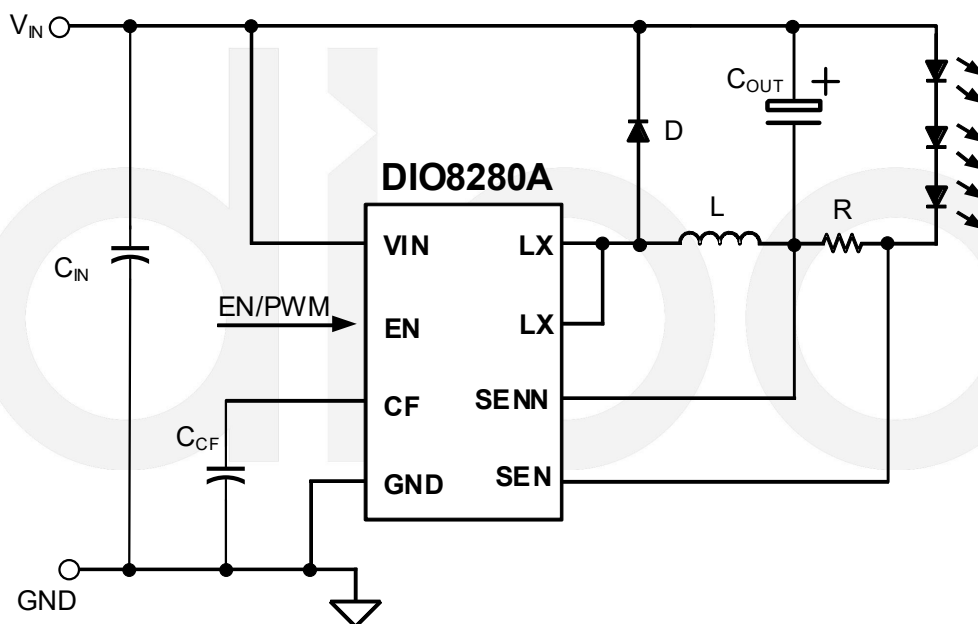

Ordering Information

Order Part Number	Top Marking		T _A	Package	
DIO8280AXS8	DIO8280 YYWW DXZ	Green	-40 to 85°C	EP-SOIC8	Tape & Reel, 2500

Pin Assignments

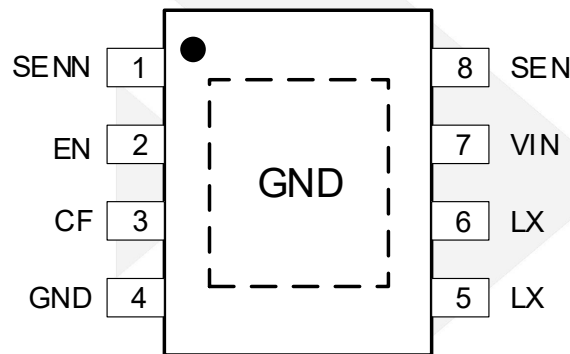

EP-SOIC8

Figure 1 Pin Assignment (Top View)

Pin Definitions

Pin Name	Description
EN	Enable pin and PWM dimming input pin.
CF	Connect a capacitor from this pin to ground to filter out the AC ripple on reference voltage. Or add 0~1.2V on this pin directly to realize linear dimming.
GND	Ground pin.
LX	Power MOSFET Drain Pin. The Drain pin is connected to the inductor node.
VIN	Input pin. Decouple this pin to GND pin with a ceramic cap.
SEN	Positive Current Sense pin.
SENN	Negative Current Sense pin.

Absolute Maximum Ratings

Stresses beyond those listed under “Absolute Maximum Rating” may cause permanent damage to the device. These are stress ratings only and functional operation of the device at these or any other condition beyond those indicated in the operational sections of the specifications is not implied. Exposure to absolute maximum rating conditions for extended periods may affect device reliability.

Parameter		Rating	Unit
LX, VIN, EN, SEN, SENN		85	V
All other pins		5.5	V
Power Dissipation, PD @ T _A =25°C		3.3	W
Package Thermal Resistance	θ _{JA}	30	°C/W
	θ _{JC}	10	
Junction Temperature Range		-40 to 150	°C
Lead Temperature		260	°C
Storage Temperature Range		-65 to 150	°C

Recommend Operating Conditions

The Recommended Operating Conditions table defines the conditions for actual device operation. Recommended Operating conditions are specified to ensure optimal performance to the datasheet specifications. DIOO does not Recommend exceeding them or designing to Absolute Maximum Ratings.

Parameter		Rating	Unit
VIN, LX, EN, SEN, SENN		16 to 80	V
All other pins		0 to 5	V
Junction Temperature Range		-40 to 125	°C

Electrical Characteristics

$V_{IN} = 24V$, $V_{OUT} = 12V$, $I_{OUT} = 100mA$, $T_A = 25^{\circ}C$, unless otherwise specified.

Symbol	Parameter	Test Conditions	Min	Typ	Max	Unit
V_{IN}	Input Voltage Range		16		80	V
I_{DN}	Shutdown Current	EN=0		10		μA
$R_{DS(ON)}$	Power MOSFET ON Resistance			200		m Ω
I_{LIMIT}	Power MOSFET Current Limit			2.8		A
F_{SW}	Switching Frequency			400		kHz
$V_{SEN-SENN}$	Current Sense Limit		196	200	204	mV
V_{ENH}	EN turn-on Threshold		1.28			V
V_{ENL}	EN turn-off Threshold				0.56	V
$V_{IN,ON}$	VIN turn-on threshold			7.4		V
$V_{IN,OFF}$	VIN turn-off threshold			6.8		V
Dimming section						
V_{CF}	Analog dimming range on CF	$I_{LED}=10\%$		120		mV
		$I_{LED}=100\%$		1.2		V
T_{SD}	Thermal Shutdown Temperature			150		$^{\circ}C$
Hyst	Thermal Hysteresis			30		$^{\circ}C$

Specifications subject to change without notice.



$$I_{LED}(A) = \frac{0.2(V)}{R_{CS}(\Omega)}$$

Input capacitor C_{VIN}:

The ripple current through input capacitor is calculated as:

$$I_{CIN_RMS} = I_{OUT} \cdot \sqrt{D(1-D)}$$

A typical X7R or better grade ceramic capacitor with suitable capacitance should be chosen to handle this ripple current well. To minimize the potential noise problem, place this ceramic capacitor really close to the VIN and GND pins. Care should be taken to minimize the loop area formed by C_{VIN}, and VIN/GND pins.

Output capacitor C_{OUT}:

The output capacitor is selected to handle the output current ripple noise requirements. For the best performance, it is recommended to use X7R or better grade ceramic capacitor greater than 1μF capacitance.

Output inductor L:

There are several considerations in choosing this inductor.

- 1) Choose the inductance to provide the desired ripple current. It is suggested to choose the ripple current to be about 40% of the maximum output current. The inductance is calculated as:

$$L = \frac{V_{OUT}(1 - V_{OUT}/V_{IN,MAX})}{F_{SW} \times I_{OUT,MAX} \times 40\%}$$

Where F_{SW} is the switching frequency and I_{OUT,MAX} is the LED current.

The DIO8280A regulator IC is quite tolerant of different ripple current amplitude. Consequently, the final choice of inductance can be slightly off the calculation value without significantly impacting the performance.

- 2) The saturation current rating of the inductor must be selected to be greater than the peak inductor current under full load conditions.

$$I_{SAT,MIN} > I_{OUT,MAX} + \frac{V_{OUT}(1 - V_{OUT}/V_{IN,MAX})}{2 \cdot F_{SW} \cdot L}$$

Dimming Operation:

It is compatible with two dimming signals: PWM signal and 0-1.2V signal.

Applied with PWM signal, the PWM is connected to EN pin, the dimming frequency is limited to larger than 20kHz. If the dimming frequency is lower than 20kHz, an external capacitor is needed to bypass CF pin.

Applied with 0-1.2V dimming, EN pin is pulled up to high, and the 0-1.2V is connected to CF pin.

Soft Start:

Add a ceramic capacitor C_{CF} on CF to achieve soft start, the soft start time can be adjusted by C_{CF}.

SCP:

If $V_{SEN}-V_{SENN}\geq 0.3V$, PWM is disabled.

EN OFF:

IC shut down after EN OFF with 8ms.

Layout Design:

The layout design of DIO8280A regulator is relatively simple. For the best efficiency and minimum noise problems, we should place the following components close to the IC: C_{VIN} , L, C_{OUT} , CF and R_{CS} .

- 1) It is desirable to maximize the PCB copper area connecting to GND pin to achieve the best thermal and noise performance. If the board space allowed, a ground plane is highly desirable.
- 2) C_{IN} must be close to Pins VIN and GND. The loop area formed by C_{IN} and GND must be minimized.
- 3) The PCB copper area associated with LX pin must be minimized to avoid the potential noise problem.



DIO8280A

High-Efficiency, 16-80V Input, 400kHz Buck CC LED Driver

CONTACT US

Dioo is a professional design and sales corporation for high-quality and performance analog semiconductors. The company focuses on industry markets, such as, cell phone, handheld products, laptop, and medical equipment and so on. Dioo's product families include analog signal processing and amplifying, LED drivers and charger IC. Go to <http://www.dioo.com> for a complete list of Dioo product families.

For additional product information, or full datasheet, please contact with our Sales Department or Representatives.

