

DIO81054 For LED Lighting

Features

- Internal 600V Power MOSFET
- Primary side CV control eliminates the opto-couple.
- Valley turn-on of the primary MOSFET to achieve low switching losses
- Power factor >0.9 @230VAC
- Reliable protection: SCP, OCP, OTP & OVP
- Quick start up:<500ms
- Low start up current:10μA typical
- Compact Package: SOIC-8

Applications

- AC/DC Adapters
- Smart Lighting
- Smart Home Systems

Descriptions

DIO81054 consists of an integrated single stage Buck & PFC Regulator and 600V power MOSFET, specifically designed for a high performance non-isolated converter with minimal external components targeting at LED lighting applications.

The DIO81054 drives the Buck converter in the quasi-resonant mode to achieve higher efficiency and keeps the Buck converter in constant on time operation to achieve high power factor.

This chip adopts special design to achieve quick start up and reliable protection for safety requirement.

Block Diagram

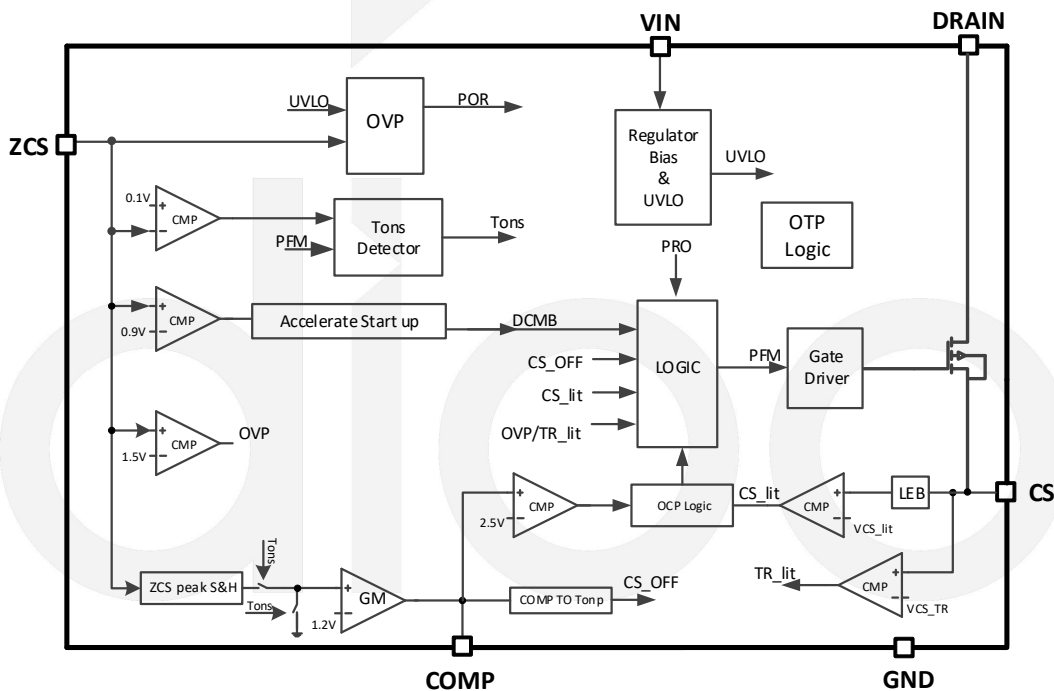

Ordering Information

Order Part Number	Top Marking		T _A	Package	
DIO81054CS8	DIO81054	Green	-40 to +85°C	SOIC-8	Tape & Reel, 2500

Pin Assignments

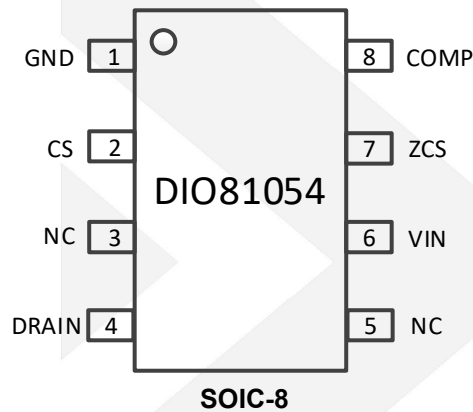

Figure 2 Pin Assignment (Top View)

Pin Definitions

Pin Name	Description
CS	Current sense pin. Connect this pin to the source of the primary switch. Connect the sense resistor across the source of the primary switch and the GND pin. Also this pin used to detect transformer and secondary is short or not.
GND	Ground pin
COMP	Loop compensation pin. Connect a RC network across this pin and ground to stabilize the control loop.
ZCS	Output voltage and Inductor current zero-crossing detection pin. This pin receives the auxiliary winding voltage by a resistor divider and detects the inductor current zero crossing point. This pin also provides over voltage protection and line regulation modification function simultaneously. If the voltage on this pin is above $V_{ZCS,OV}$, the IC would enter over voltage protection mode. Good line regulation can be achieved by adjusting the upper resistor of the divider
VIN	Power supply pin.
DRAIN	Power MOSFET Drain Pin. The Drain pin is connected to the primary lead of the transformer.
NC	Not Connect.

Absolute Maximum Ratings

Stresses beyond those listed under “Absolute Maximum Rating” may cause permanent damage to the device. These are stress ratings only and functional operation of the device at these or any other condition beyond those indicated in the operational sections of the specifications is not implied. Exposure to absolute maximum rating conditions for extended periods may affect device reliability.

Parameter		Rating	Unit
VIN, DRV		-0.3 to 33	V
DRAIN		600	V
Supply Current I _{VIN}		15	mA
ZCS		-0.3 to VIN+0.3	V
CS, COMP		-0.3 to 5	V
Power Dissipation, P _D @ T _A = 25°C, SOIC-8		1.1	W
Package Thermal Resistance, SOIC-8	θ _{JA}	100	°C/W
		50	
Storage Temperature Range		-65 to 150	°C
Junction Temperature Range		150	°C
Lead Temperature Range		260	°C
ESD	HBM, JEDEC: JESD22-A114	2000	V
	MM, JEDEC: JESD22-A115	200	

Recommend Operating Conditions

The Recommended Operating Conditions table defines the conditions for actual device operation. Recommended Operating conditions are specified to ensure optimal performance to the datasheet specifications. DIOO does not Recommend exceeding them or designing to Absolute Maximum Ratings.

Parameter	Rating	Unit
Supply Voltage	9.5 to 27	V
Junction Temperature Range	-40 to 125	°C
Ambient Temperature Range	-40 to 85	°C



DIO81054

Single Stage Buck PFC Regulator with CV Control For LED Lighting For LED Lighting

Electrical Characteristics

$T_A = 25^\circ\text{C}$, $V_{IN} = 12\text{V}$, unless otherwise specified.

Symbol	Parameter	Test Conditions	Min	Typ	Max	Unit
Power Supply Section						
$V_{VIN,ON}$	VIN turn-on threshold			16.5		V
$V_{VIN,OFF}$	VIN turn-off threshold			8.5		V
$V_{VIN,OVP}$	VIN OVP voltage			27		V
I_{ST}	Start up Current	$V_{VIN} < V_{VIN,OFF}$		10		μA
I_{VIN}	Operating Current	$C_L = 100\mu\text{F}$, $f = 15\text{kHz}$		1		mA
$I_{VIN,OVP}$	Shunt current in OVP mode	$V_{VIN} > V_{VIN,OVP}$		2.5		mA
Error Amplifier Section						
V_{REFV}	Internal reference voltage		1.17	1.2	1.22	V
ZCS pin Section						
$V_{ZCS,LOW}$	V_{ZCS} at fast respond			1.05		V
$V_{ZCS,HIGH}$	Threshold value of Max V_{ZCS}			1.4		V
$V_{ZCS,OVP}$	OVP voltage threshold			1.5		V
Current Sense Section(Source PIN of integrated MOSFET)						
$V_{CS,LIMIT}$	Current limit Voltage	$ZCS < 0.2\text{V}$		0.45		V
		$1.0\text{V} > ZCS > 0.2\text{V}$		1.05		V
PWM Section						
$t_{OFF,MIN1}$	Blanking time for OFF time	$V_{CS\ HOLD} = 0.15\text{V}$		1.2		μs
$t_{OFF,MIN2}$		$V_{CS\ HOLD} = 0.40\text{V}$		1.5		μs
T_{LEB}	Leading edge blanking time			300		ns
$t_{ON,MAX}$	Max ON Time	$V_{COMP} = 2.7\text{V}$		12		μs
$t_{ON,MIN}$	Min ON Time			0.42		μs
f_{MAX}	Maximum switching frequency			105		kHz
Power MOSFET Section						
V_{BVDSS}	Break-down Voltage	$I_{DS} = 250\mu\text{A}$, $T_J = 25^\circ\text{C}$	600	630	650	V
I_{DSS}	Off-state drain current	$V_{DS} = 600\text{V}$, $V_{GS} = 0\text{V}$, $T_J = 25^\circ\text{C}$	0.01		1	μA
Thermal Section						
T_{SD}	Thermal Shutdown Temperature			150		$^\circ\text{C}$

Typical Application

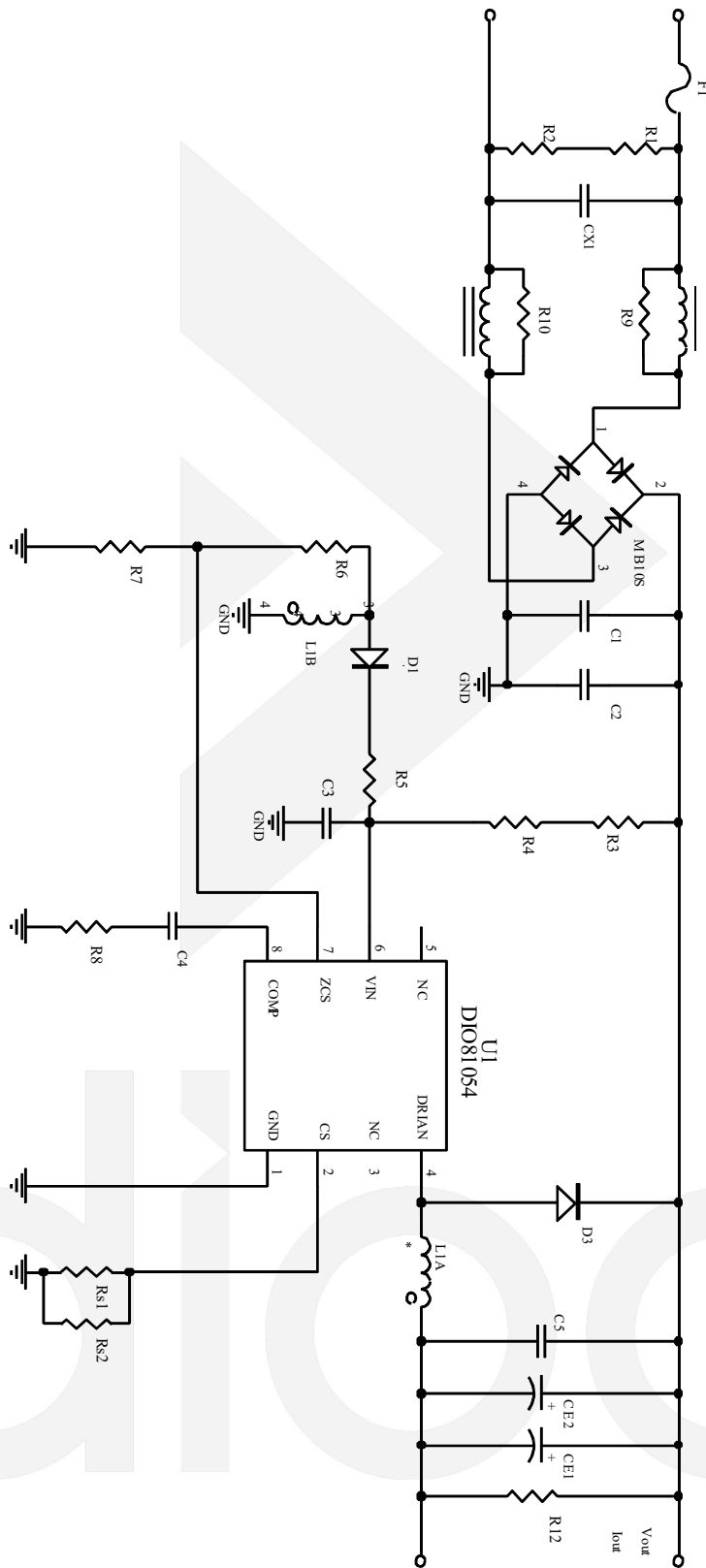

Figure 3 Typical Application



DIO81054

Operation

DIO81054 is a constant voltage Buck regulator with PFC function that targets at LED lighting applications.

Application Information

Start up

After AC or DC supply is powered on, the capacitor C_{VIN} across VIN and GND pin is charged up by BUS voltage through a start up resistor R_{ST} . Once V_{VIN} rises up to V_{VIN-ON} , the internal blocks start to work and PWM output is enabled. The output voltage is feedback by ZCS pin, which is taken as V_{FB} . If V_{FB} is lower than certain threshold $V_{ZCS,ST}$, which means the output voltage is not built up, V_{COMP} is pulled up to high clamped; if V_{FB} is higher than $V_{ZCS,ST}$, V_{COMP} is under charge of the internal gain modulator.

Shut down

After AC supply or DC BUS is powered off, the energy stored in the BUS capacitor will be discharged. When the auxiliary winding of Flyback transformer can't supply enough energy to VIN pin, V_{VIN} will drop down. Once V_{VIN} is below $V_{VIN-OFF}$, the IC will stop working and V_{COMP} will be discharged to zero.

Quasi-Resonant Operation

QR mode operation provides low turn-on switching losses for Flyback & Buck converter.

Over Voltage Protection (OVP)

The output voltage is reflected by the auxiliary winding voltage of the Flyback & Buck transformer, and both ZCS pin and VIN pin provide over voltage protection function. When the load is null or large transient happens, the output voltage will exceed the rated value. When V_{VIN} exceeds $V_{VIN,OVP}$ or V_{ZCS} exceeds $V_{ZCS,OVP}$, the over voltage protection is triggered and the IC will discharge V_{VIN} by an internal current source $I_{VIN,OVP}$. Once V_{VIN} is below $V_{VIN,OFF}$, the IC will shut down and be charged again by BUS voltage through start up resistor. If the overvoltage condition still exists, the system will operate in hiccup mode.

Short Circuit Protection (SCP)

When the output is shorted to ground, the output voltage is clamped to zero. The voltage of the auxiliary winding is proportional to the output winding, so valley signal cannot be detected by ZCS. Without valley detection, MOSFET cannot be turned ON until maximum off time $t_{OFF,MAX}$ is matched. If MOSFET is turned ON by $t_{OFF,MAX}$ 64 times continuously, IC will be shut down and enter into hiccup mode. If the output voltage is not low enough to disable valley detection in short condition, V_{VIN} will dropdown without auxiliary winding supply. Once V_{VIN} is below $V_{VIN,OFF}$, the IC will shut down and be charged again by the BUS voltage through the start up resistor. If the short circuit condition still exists, the system will operate in hiccup mode.

The voltage across drain and source of the primary MOSFET is reflected by the auxiliary winding of the Flyback transformer. ZCS pin detects the voltage across the auxiliary winding by a resistor divider. When the voltage across drain and source of the primary MOSFET is at voltage valley, the MOSFET would be turned on.



DIO81054

Optimized Design For Load Transient

In order to achieve good transient performance, optimized design is adopted.

When ZCS touch $V_{ZCS,HIGH}$, IC work at Low Frequency mode to decrease output energy, and COMP is pulled down to decrease the energy output.

When ZCS touch $V_{ZCS,LOW}$, IC work at CS limit mode to expedite output energy, and COMP is charged to increase the energy output.

Single Stage Buck PFC Regulator with CV Control For LED Lighting For LED Lighting





DIO81054

Single Stage Buck PFC Regulator with CV Control For LED Lighting For LED Lighting

CONTACT US

Dioo is a professional design and sales corporation for high-quality and performance analog semiconductors. The company focuses on industry markets, such as, cell phone, handheld products, laptop, and medical equipment and so on. Dioo's product families include analog signal processing and amplifying, LED drivers and charger IC. Go to <http://www.dioo.com> for a complete list of Dioo product families.

For additional product information, or full datasheet, please contact with our Sales Department or Representatives.

dioo