

# DIO1280C

## Over-Voltage Protection Load Switch

### Features

- Surge Protection  
IEC 61000-4-5: >100V
- Over-Voltage Protection (OVP)
- Over-Temperature Protection (OTP)
- ESD Protection  
IEC 61000-4-2 Air Discharge: >15kV  
IEC 61000-4-2 Contact Discharge: >8kV
- +/-100V EOS Protection
- Negative Voltage Protection(-30V)

### Applications

- Mobile Handsets and Tablets
- Portable Media Players
- MP3 Players

### Descriptions

The DIO1280C features a low-  $R_{ON}$  internal FET and an operating range of  $2.5V_{DC}$  to  $25V_{DC}$  (absolute maximum of  $30V_{DC}$ ). An internal clamp is capable of shunting surge voltages >100V, protecting downstream components and enhancing system robustness. The DIO1280C features over-voltage protection that powers down the internal FET if the input voltage exceeds the OVP threshold. Over-temperature protection also powers down the device at  $130^{\circ}C$  (typical). Exceptionally low off-state current (< $1\mu A$  maximum) facilitates compliance with standby power requirements.

The DIO1280C is available in a fully “green” compliant  $1.3mm \times 1.8mm$  Wafer-Level Chip-Scale Package (WLCSP) with backside laminate.

### Function Block Diagram

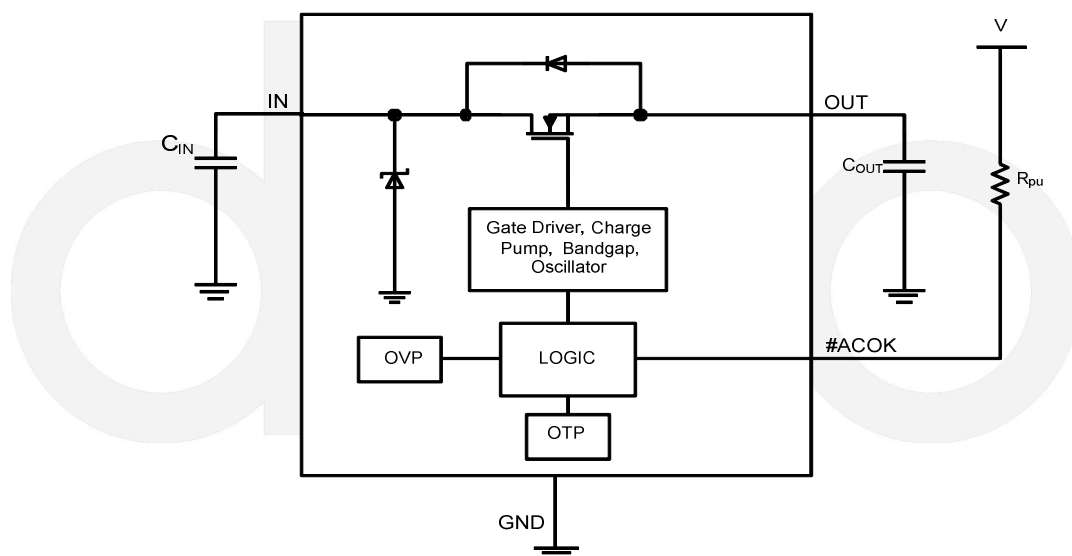
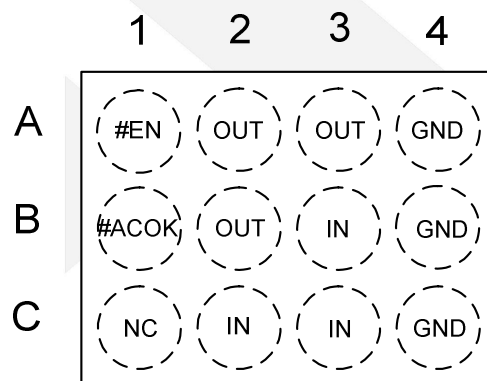

Figure 1 Functional Block Diagram

## Ordering Information

Order Part Number	Top Marking		T <sub>A</sub>	Package	
DIO1280CWL12	HD80	Green	-40 to 85°C	WLCSP-12 0.4mm pitch	Tape & Reel, 3000

## Pin Configuration



WLCSP-12

Figure 2 Pin Assignment (Top View)

## Pin Definitions

Name	Bump	Type	Description		
IN	B3,C2,C3	Input/Supply	Switch Input and Device Supply		
OUT	A2,A3,B2	Output	Switch Output to Load		
#ACOK	B1	Output	Power Good	1	$V_{IN} < V_{IN\_min}$ OR $V_{IN} \geq V_{OVLO}$
				0	Voltage Stable
#EN	A1	Input	Device Enable, Low is enable.		
GND	A4,B4,C4	Supply	Device Ground		
NC		NC	No Connect		



# DIO1280C

Over-Voltage Protection Load Switch

## Absolute Maximum Ratings

Stresses beyond those listed under “Absolute Maximum Rating” may cause permanent damage to the device. These are stress ratings only and functional operation of the device at these or any other condition beyond those indicated in the operational sections of the specifications is not implied. Exposure to absolute maximum rating conditions for extended periods may affect device reliability.

Symbol	Parameter	Rating	Unit	
$V_{IN}$	$V_{IN}$ to GND	-30 to 30	V	
$V_{OUT}$	$V_{OUT}$ to GND	-0.3 to $V_{IN}+0.3$	V	
$V_{\#EN\_ACOK}$	Maximum DC Voltage Allowed on #EN or ACOK Pin	6	V	
$I_{IN}$	Switch I/O Current (Continuous)	4.5	A	
$t_{PD}$	Total Power Dissipation at $T_A=25^{\circ}C$	1.48	W	
$T_{STG}$	Storage Temperature Range	-65 to 150	$^{\circ}C$	
$T_J$	Maximum Junction Temperature	150	$^{\circ}C$	
$T_L$	Lead Temperature (Soldering, 10 Seconds)	260	$^{\circ}C$	
$\theta_{JA}$	Thermal Resistance, Junction-to-Ambient	84.1	$^{\circ}C/W$	
ESD	IEC 61000-4-2 System ESD	Air Gap	15.0	kV
		Contact	8.0	
Surge	IEC 61000-4-5, Surge Protection	$V_{IN}$	100	V

## Recommended Operating Conditions

The Recommended Operating Conditions table defines the conditions for actual device operation. Recommended Operating conditions are specified to ensure optimal performance to the datasheet specifications. DIOO does not Recommend exceeding them or designing to Absolute Maximum Ratings.

Symbol	Parameter	Min	Typ.	Max	Unit
$V_{IN}$	Supply Voltage	2.5		25	V
$T_A$	Operating Temperature	-40		85	$^{\circ}C$
$I_{OUT}$	Output Current			3	A



# DIO1280C

Over-Voltage Protection Load Switch

## Electrical Characteristics

$T_A = -40^{\circ}\text{C}$  to  $85^{\circ}\text{C}$ , unless otherwise specified. Typical values are  $V_{IN} = 5.0\text{V}$ ,  $I_{IN} \leq 3\text{A}$ ,  $C_{IN} = 0.1\mu\text{F}$  and  $T_A = 25^{\circ}\text{C}$ .

Symbol	Parameter	Test Conditions	Min	Typ.	Max	Unit
$V_{IN\_CLAMP}$	Input Clamping Voltage	$I_{IN} = 10\text{mA}$		35		V
$I_Q$	Input Quiescent Current	$V_{IN} = 5\text{V}$ , #EN=0V		80	110	$\mu\text{A}$
$V_{OVLO}$	Internal Over-Voltage Trip Level	$V_{IN}$ Rising	5.7	5.85	6.0	V
$V_{OVLOH}$	Internal Over-Voltage Trip Level Hysteresis		50	100	150	mV
$V_{UVLO}$	Under Voltage Trip Level	$V_{IN}$ Rising		2.25	2.4	V
		$V_{IN}$ Falling		1.95	2.1	V
$R_{ON}$	Resistance from $V_{IN}$ to $V_{OUT}$	$V_{IN} = 5\text{V}$ , $I_{OUT} = 1\text{A}$ , $T_A = 25^{\circ}\text{C}$		30		$\text{m}\Omega$
$C_{OUT}$	OUT Load Capacitance	$V_{IN} = 5\text{V}$			1000	$\mu\text{F}$
$T_{SDN}$	Thermal Shutdown			130		$^{\circ}\text{C}$
$T_{SDN\_HYS}$	Thermal Shutdown Hysteresis			20		$^{\circ}\text{C}$
<b>Digital Signals</b>						
$V_{OL}$	#ACOK Output Low Voltage	$I_{SINK} = 1\text{mA}$			0.4	V
$V_{IH\_}\#EN$	Enable HIGH Voltage	$V_{IN} = 2.5\text{V}$ to $V_{OVLO}$	1.2			V
$V_{IL\_}\#EN$	Enable LOW Voltage	$V_{IN} = 2.5\text{V}$ to $V_{OVLO}$			0.5	V
$I_{ACOK\_LEAK}$	#ACOK Leakage Current	$V_{ACOK} = 3\text{V}$ , #ACOK Deasserted	-0.5		0.5	$\mu\text{A}$
#EN_Leak	#EN Leakage Current	$V_{IN} = 5.0\text{V}$ , $V_{OUT} = \text{Float}$	-1.0		1.0	$\mu\text{A}$
<b>Timing Characteristics</b>						
$t_{DEB}$	Debounce Time	Time from $2.5\text{V} < V_{IN} < V_{OVLO}$ to $V_{OUT} = 0.1 \times V_{IN}$		15		ms
$t_{START}$	Soft-Start Time	Time from $V_{IN} = V_{IN\_min}$ to $0.2 \times \#ACOK$ , $V_{IO} = 1.8\text{V}$ with $10\text{k}\Omega$ Pull-up Resistor		30		ms
$t_{ON}$	Switch Turn-On Time	$R_L = 100\Omega$ , $C_L = 22\mu\text{F}$ , $V_{OUT}$ from $0.1 \times V_{IN}$ to $0.9 \times V_{IN}$		2		ms
$t_{OFF}$	Switch Turn-Off Time	$R_L = 100\Omega$ , $C_L = 0\mu\text{F}$ , $V_{IN} > V_{OVLO}$ to $V_{OUT} = 0.8 \times V_{IN}$		125		ns

Specifications subject to change without notice.

## Timing Diagrams:

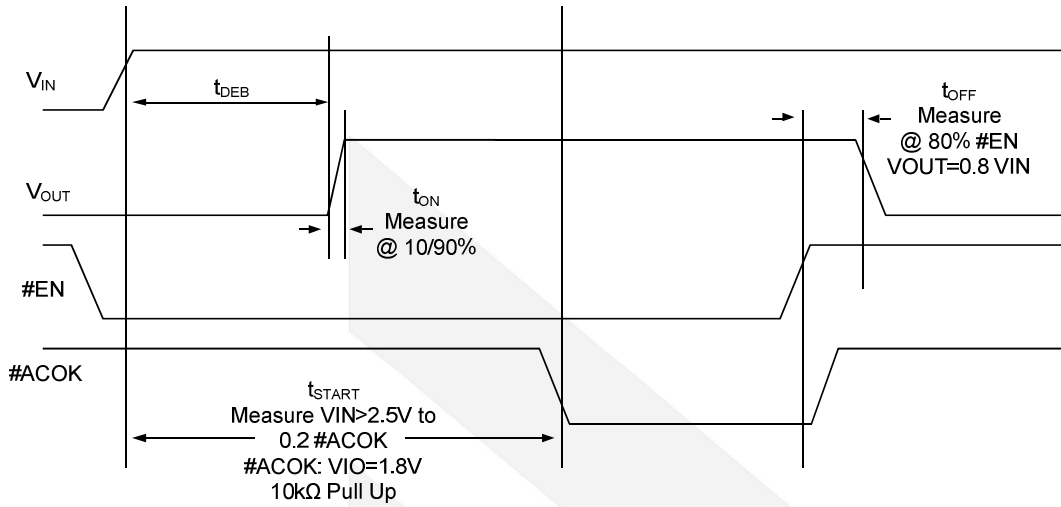

Figure 3 Timing for Power Up and Normal Operation





# DIO1280C

Over-Voltage Protection Load Switch

## Typical Performance Characteristics

Ambient temperature is 25°C,  $V_{IN}=5V$ ,  $I_{IN}\leq 3A$ ,  $C_{IN}=1\mu F$ ,  $C_{OUT}=1\mu F$ , unless otherwise noted.

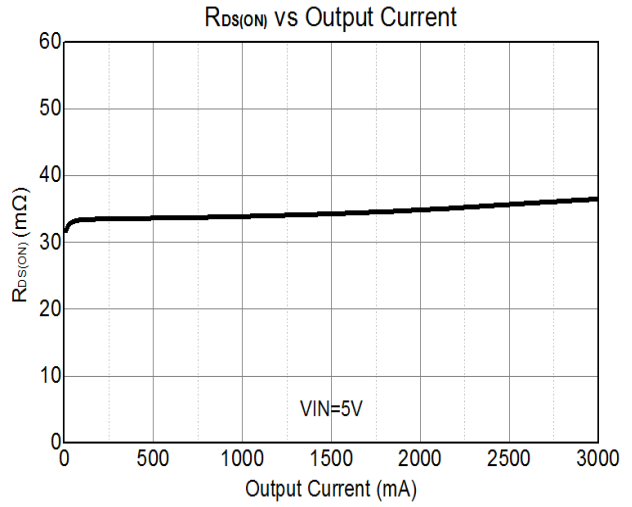
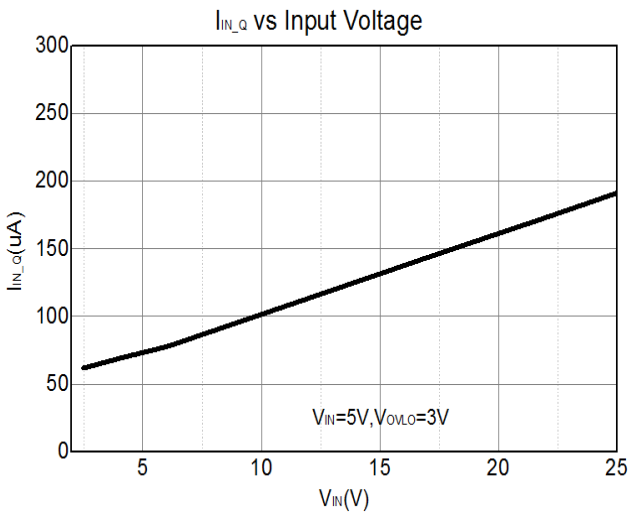

VIN Power ON ( $V_{IN}=5V$ , No Load)

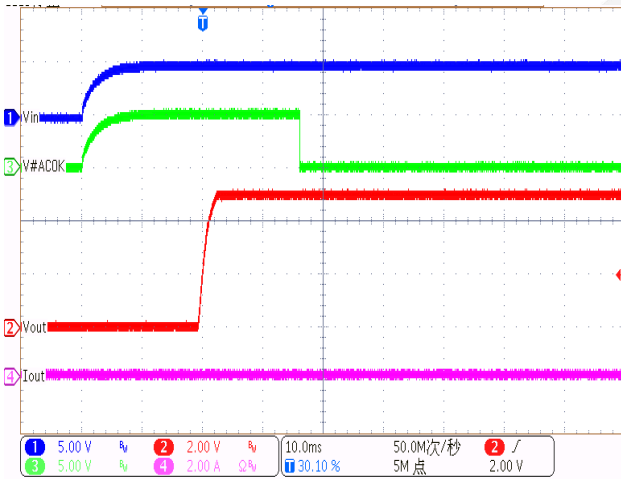

VIN Power OFF ( $V_{IN}=5V$ , No Load)

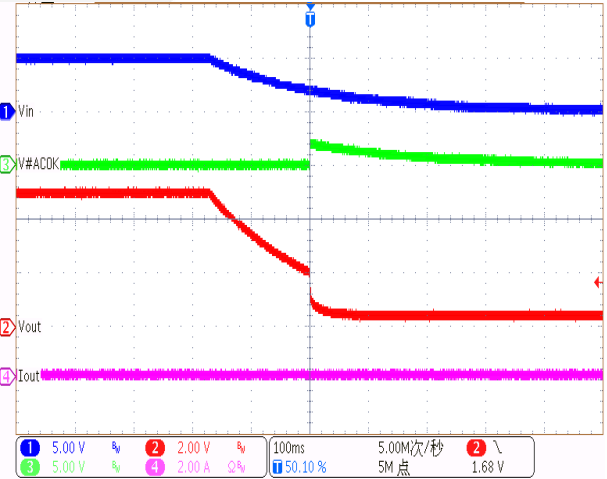

VIN Power ON ( $V_{IN}=5V$ ,  $R_{Load}=1.6\Omega$ )

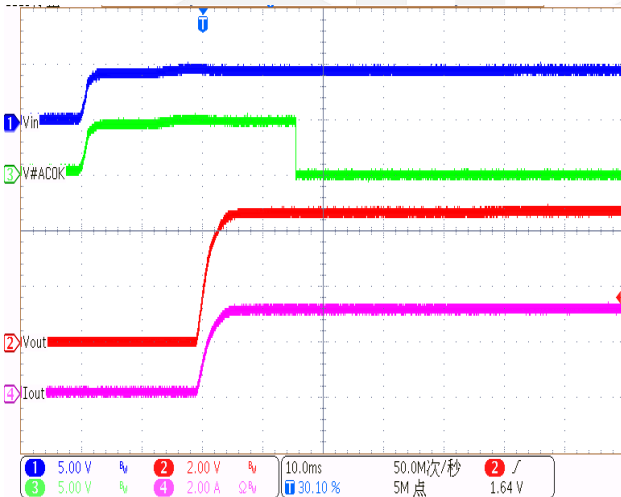

VIN Power OFF ( $V_{IN}=5V$ ,  $R_{Load}=1.6\Omega$ )

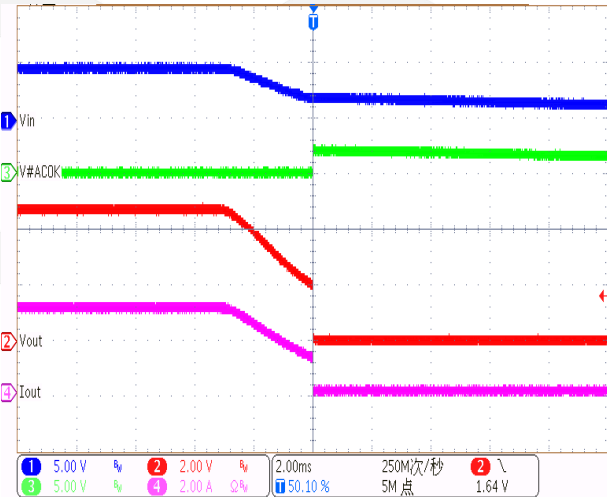

EN Power ON ( $V_{IN}=5V$ , No Load)

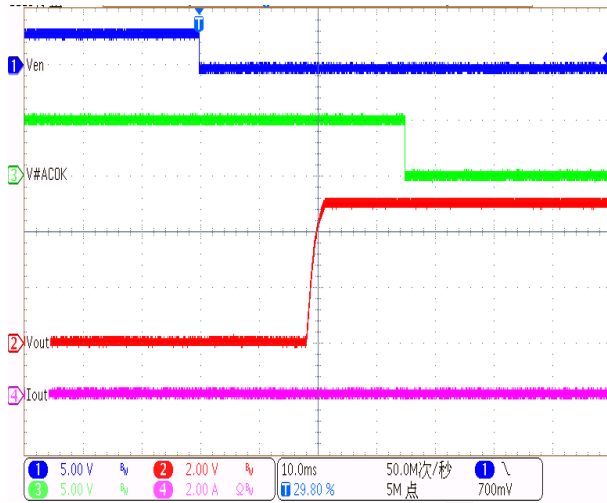

EN Power OFF ( $V_{IN}=5V$ , No Load)

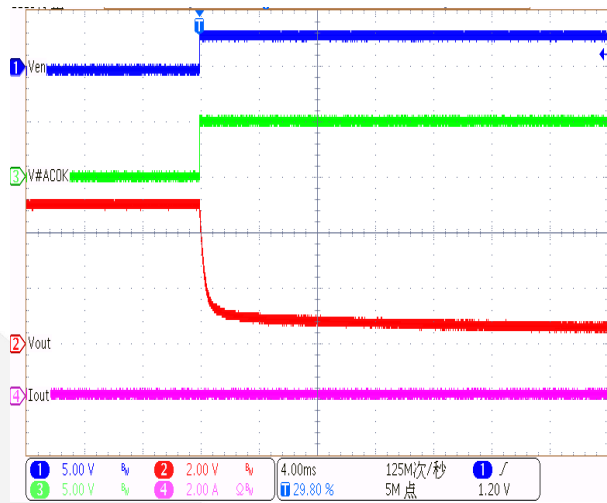

EN Power ON ( $V_{IN}=5V$ ,  $R_{Load}=1.6\Omega$ )

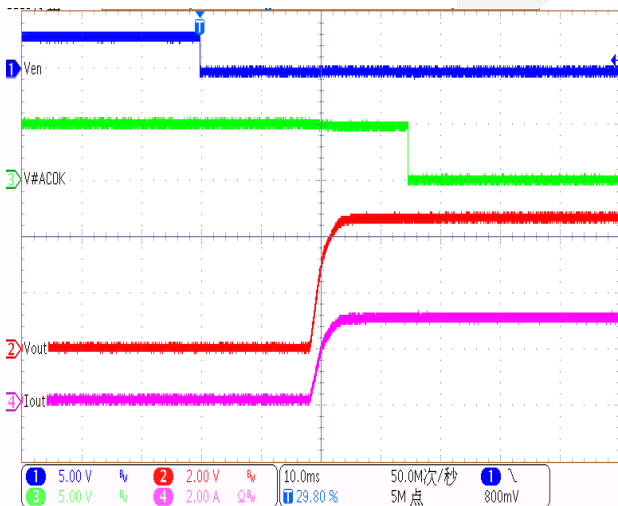

EN Power OFF ( $V_{IN}=5V$ ,  $R_{Load}=1.6\Omega$ )

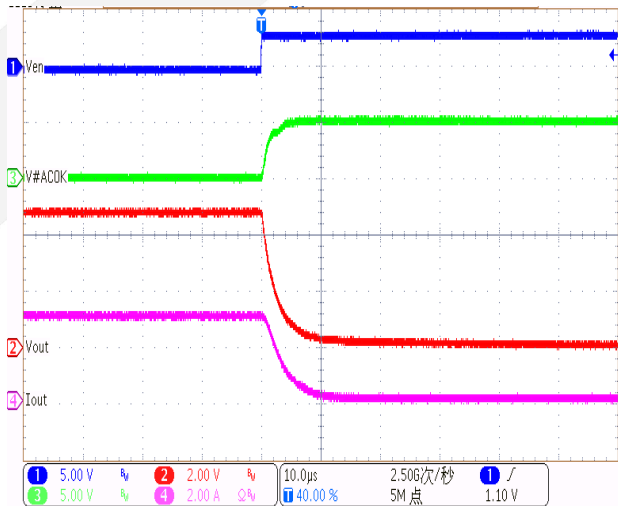

## On-The-Go (OTG) Functionality:

During OTG operation, the DIO1280C is initially disabled and the power FET's bulk diode is forward biased. The bulk diode represents  $\sim 0.7V$  drop across the device, which remains until the  $V_{IN}$  voltage increases past  $2.5V$ , when the device is fully enabled. While the device is disabled and the body diode is forward biased, the max DC current through the diode is  $1.8A$ . This current is limited by the thermal performance of the device ( $0.7V \times 1.8A = 1.36W$ ). The #EN pin must be pulled LOW to ensure the device fully enables and the transient should not exceed the RC time constant of the  $C_{IN}$  and  $C_{OUT}$  capacitors. At the system level, over-voltage and current protection should be provided outside the DIO1280C.



## DIO1280C

### CONTACT US

**Dioo** is a professional design and sales corporation for high-quality and performance analog semiconductors. The company focuses on industry markets, such as, cell phone, handheld products, laptop, and medical equipment and so on. Dioo's product families include analog signal processing and amplifying, LED drivers and charger IC. Go to <http://www.dioo.com> for a complete list of Dioo product families.

For additional product information, or full datasheet, please contact with our Sales Department or Representatives.

dioo