

DIO8210

Adaptive 100/120Hz Current Ripple Remover

Max LED Current $\leq 350\text{mA}$

Features

- Wide input voltage range from 10V up to 85V
- Internal 85V power MOSFET
- Adaptive 100/120Hz current ripple remover for dimmable LED luminaries with wide input current range from 50mA up to 350mA
- LED voltage low to 0.4V when LED current is 350mA
- Multiple protection features:
 - ◇ Reliable LED voltage limit
 - ◇ Reliable LED current limit
 - ◇ Reliable Short LED Protection (SLP)
 - ◇ Hot-plug protection
 - ◇ Over Temperature Protection (OTP)
- EP-SOIC8 package

Descriptions

DIO8210 is used to drive a LED string ($\leq 75\text{V}$), and remove the 100/120Hz current ripple on AC/DC power by a capacitor between VC and GND.

If the voltage on LED pin exceeds 6V, the current ripple removing function is disabled, which could help limit the power dissipation on chip. DIO8210 provides short protection, open protection and HOT-PLUG protection.

The maximum LED current is internally limited at 0.5A.

DIO8210 provides over thermal protection. When the OTP is triggered, the internal MOSFET shuts down until the temperature decreases to 120°C .

Applications

- Flickerless LED lighting

Block Diagram

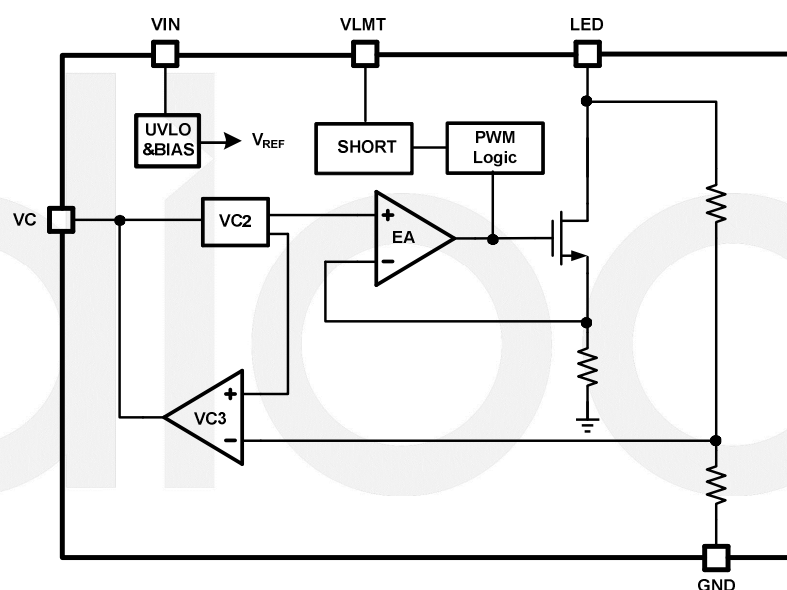

Ordering Information

Order Part Number	Top Marking		T _A	Package	
DIO8210XS8	DIO8210	Green	-40 to +150°C	EP-SOIC8	Tape & Reel, 2500

Pin Assignments

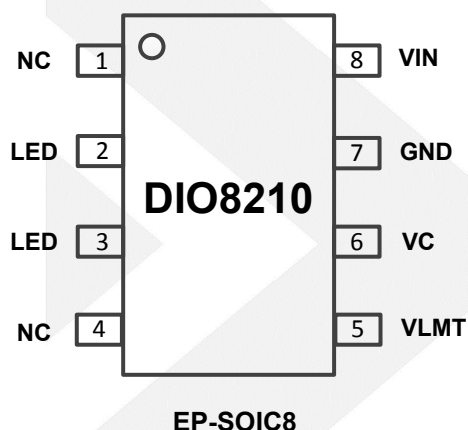

EP-SOIC8

Figure 1 Pin Assignment (Top View)

Pin Definitions

Pin Name	Description
VIN	Power Supply voltage input
LED	Connect to Cathode of LED string
GND	Ground
VLMT	Adjustable LED Short Protection Threshold
VC	Adjustable LED Current Ripple. By connecting a capacitor between VC to GND to regulate the current ripple.

Absolute Maximum Ratings

Stresses beyond those listed under “Absolute Maximum Rating” may cause permanent damage to the device. These are stress ratings only and functional operation of the device at these or any other condition beyond those indicated in the operational sections of the specifications is not implied. Exposure to absolute maximum rating conditions for extended periods may affect device reliability.

Parameter	Rating	Unit
VIN	85	V
LED	-0.3 to 85	V
VC, VLMT	-0.3 to 6	V
Junction Temperature	150	°C
Lead Temperature	260	°C
Storage Temperature	-65 to +150	°C
Thermal Resistance / θ_{JA}	45	°C/W

Recommend Operating Conditions

The Recommended Operating Conditions table defines the conditions for actual device operation. Recommended Operating conditions are specified to ensure optimal performance to the datasheet specifications. DIOO does not Recommend exceeding them or designing to Absolute Maximum Ratings.

Parameter	Rating	Unit
VIN	10 to 75	V
LED	<85	V
Maximum Junction Temperature (T_J)	150	°C



DIO8210

Adaptive 100/120Hz Current Ripple Remover, Max Input Current ≤ 350mA

Electrical Characteristics

T_A = 25°C, V_{IN} = 12V, C_C = 1μF, unless otherwise specified.

Symbol	Parameter	Test Conditions	Min	Typ	Max	Unit
V _{IN_ON}	V _{IN} Power On Voltage Threshold			10		V
V _{IN_OFF}	V _{IN} Power Off Voltage Threshold			6		V
I _{IN_OP}	V _{IN} Operation Current	I _{LED} = 300mA		0.25		mA
V _{LED_LIMIT}	LED Voltage Limit Threshold	LED voltage when voltage limit is triggered	5.4	6	6.6	V
V _{TH_SHORT}	LED Short Protection Threshold	VLMT voltage when LED short protection is triggered	1.8	2	2.2	V
T _{SP}	LED Short Protection Delay Time			60		μs
T _{SH}	LED Short Protection Hold Time			10		ms
V _{LED_MIN}	Min LED Pin Voltage when operation	I _{LED} = 300mA		0.60		V
I _{LIMIT}	LED Current Limit			0.5		A
T _{SD}	Thermal Shutdown Threshold		125	140		°C
T _{HYST}	Thermal Shutdown Hysteresis			25		°C



Typical System Characteristics

$V_{IN}=176V\sim 264Vac$, $V_{OUT}=72V$, $I_{OUT}=240mA$, $C_{OUT}=100\mu F/100V*2$, $T_A=25^{\circ}C$.

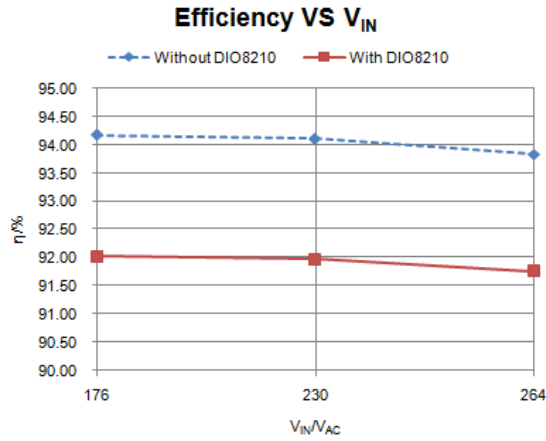

Current Ripple without DIO8210

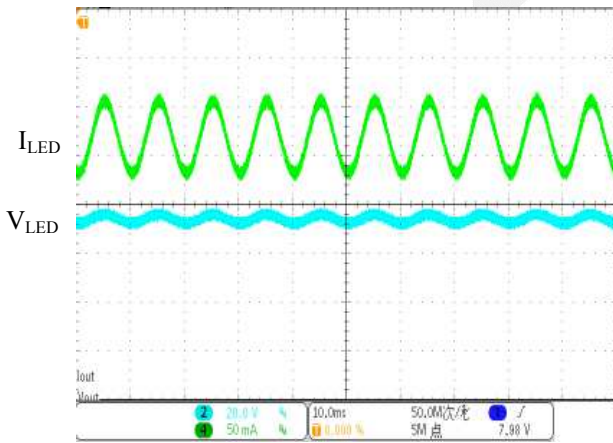

I_{LED} : 50mA/div

V_{LED} : 20V/div

Current Ripple with DIO8210

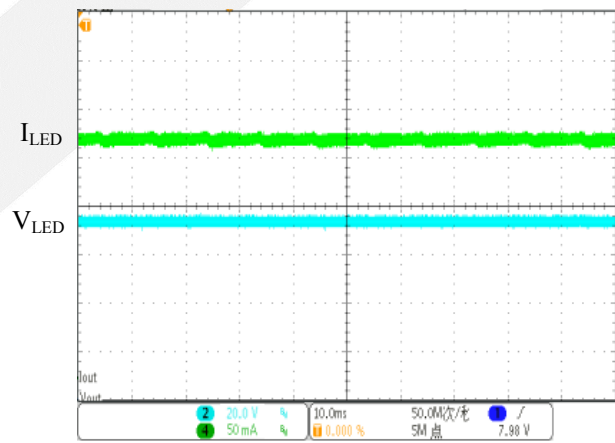

I_{LED} : 50mA/div

V_{LED} : 20V/div

Power ON

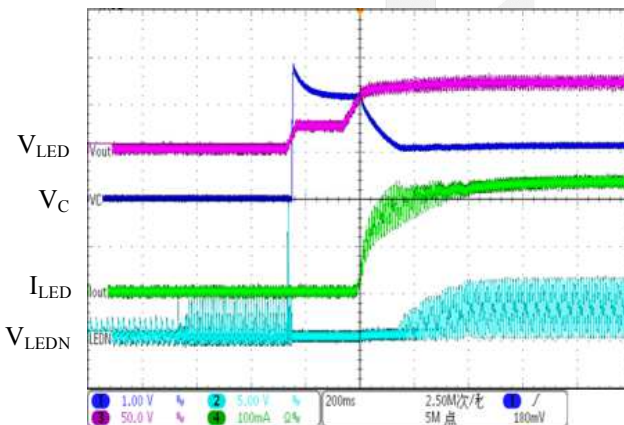

V_C : 1V/div

V_{LEDN} : 5V/div

I_{LED} : 100mA/div

V_{LED} : 50V/div

LED Hot plug test

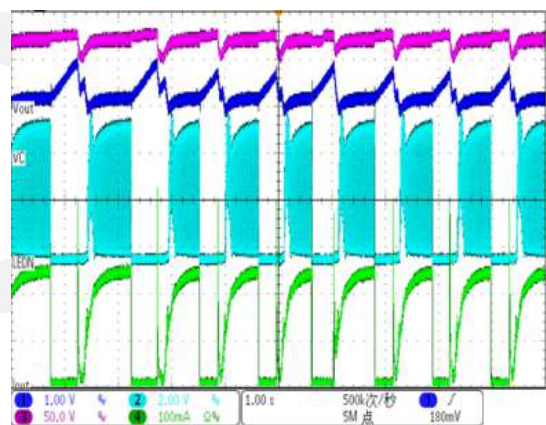

V_C : 1V/div

V_{LEDN} : 2V/div

I_{LED} : 100mA/div

V_{LED} : 50V/div

Line Input arcing test

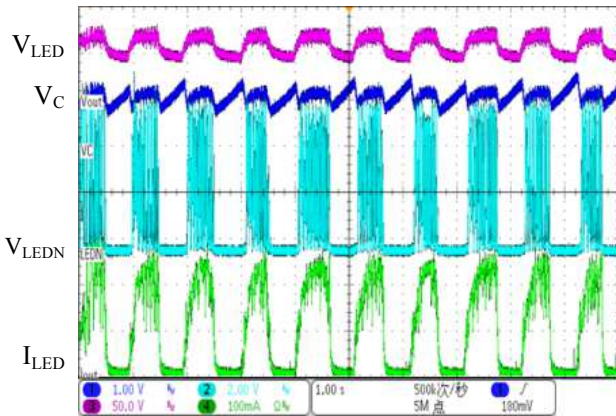

V_C : 1V/div V_{LEDN} : 2V/div
 V_{LED} : 100mA/div V_{LED} : 50V/div

Dimming application test

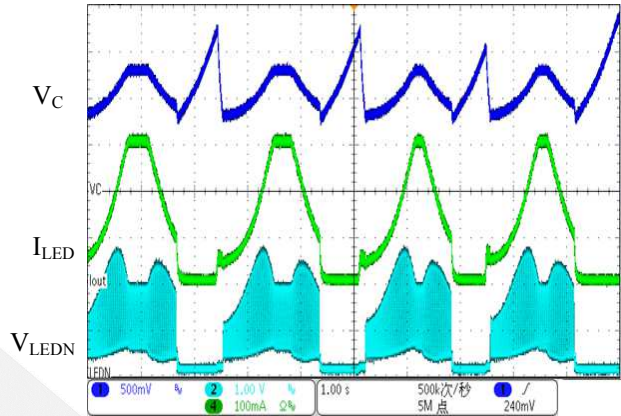

V_C : 500mV/div V_{LEDN} : 1V/div
 I_{LED} : 100mA/div

LED Open Protection test

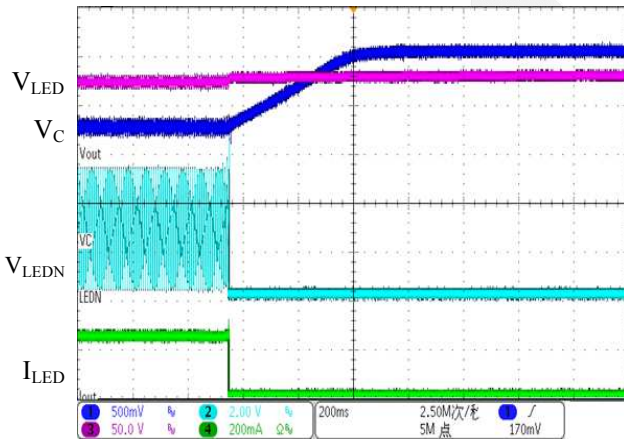

V_C : 500mV/div V_{LEDN} : 2V/div
 I_{LED} : 200mA/div V_{LED} : 50V/div

LED Short Protection test

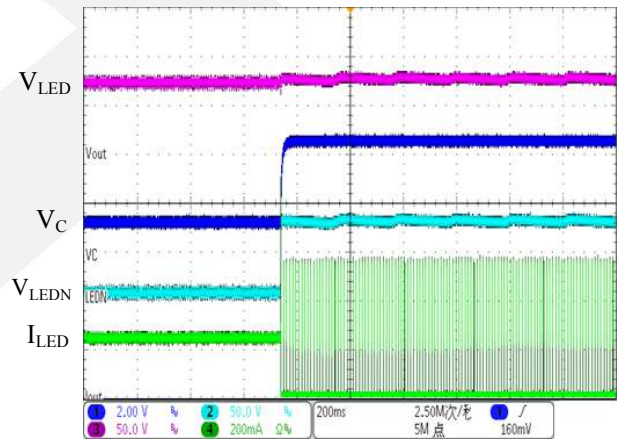

V_C : 2V/div V_{LEDN} : 50V/div
 I_{LED} : 200mA/div V_{LED} : 50V/div



Application Information

Theory of Operation

DIO8210 is a secondary side LED current ripple remover which is designed for single stage LED driver, supplied by an AC/DC current source with the LED string. The LED pin is connected to the cathode of LED string. DIO8210 transfers the LED current ripple to voltage ripple on chip, and ensures the constant voltage across LED string and the current flow through LED string.

The scalable adaptive function of DIO8210 can regulate the cathode voltage of LED string to minimum to improve the efficiency of the system.

Current Ripple Removing

The capacitor C_C between VC and GND is an integration capacitor. DIO8210 transform the voltage on C_C to a reference voltage. The current regulator regulates LED current via negative feedback control.

C_C should be large enough in order to remove the current ripple of the LED string. However, too large capacitor may slow down the dynamic response.

Adaptive Regulation

DIO8210 control the voltage on C_C by monitoring the operation state of built-in NMOSFET. The efficiency of system is relatively low when NMOSFET always work in the saturation region. DIO8210 detects it and charges C_C to raise the V_{VC} and I_{LED} , then the output voltage of power supply is reduced, and the voltage drop on NMOSFET decreases.

Conversely, when NMOSFET is working in the linear region, LED current regulation loop is open. DIO8210 detects it and discharges C_C to reduce the V_{VC} and I_{LED} , then the output voltage of power supply is raised, and the LED current regulation loop is close.

LED Pin Voltage Limit

The voltage ripple on LED pin is very large when the current ripple is removed, which would bring large power dissipation on chip. DIO8210 limit the voltage on LED pin as 6V internally. When the voltage on LED pin reaches 6V, the current ripple removing function is blocked.

LED Current Limit

The current of LED is limited to 0.5A internally. The current limitation can protect the chip when LED is short connected or HOT-PLUG.

The function of current limit is higher priority than LED Pin voltage limit. It means that the voltage on LED Pin is limited when LED current exceed 0.5A.

LED Short Protection

The resistor divider connected between LED and GND can setup the Short protection threshold. When the voltage input to V_{LMT} Pin is exceed 2V and the state holds for more than 60 μ s, DIO8210 considers the LED string is short connected, and shut down the internal MOSFET.

The shut down state is latched for 10ms hold time. After 10ms, the short state is reset, and the MOSFET restart.

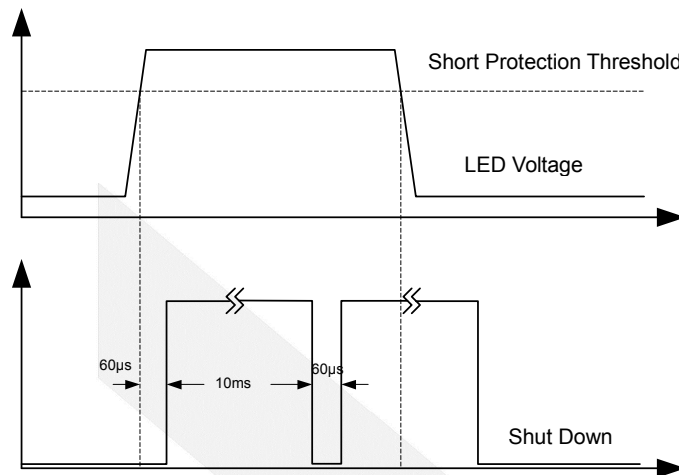

The short protection threshold is calculated as below:

$$V_{TH_V_{LMT}} = 2V * (R_1 + R_2) / R_2$$

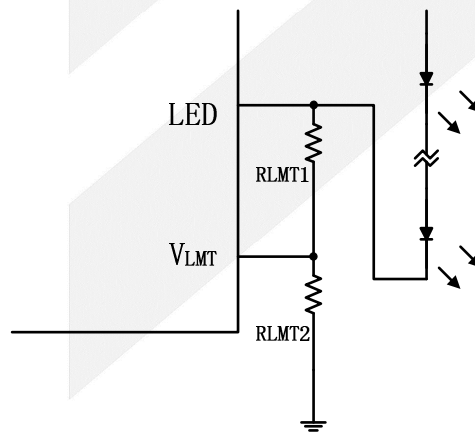

Open and HOT-PLUG Protection

When DIO8210 detects that LED current is lower than 50mA, and the state holds for more than 60µs, DIO8210 considers the LED string is open connected, and shuts down the internal MOSFET. The shut down state is latched for 0.5ms hold time. The MOSFET restart after 0.5ms.

If the LED string is connected suddenly during MOSFET restart, the open state is reset, internal MOSFET is turned on and the LED current is limited at 0.5A.

Over Thermal Protection

DIO8210 monitors operation temperature. When the temperature is higher than 150°C, the internal MOSFET is shut down until the temperature drop to 130°C.

Application Reference

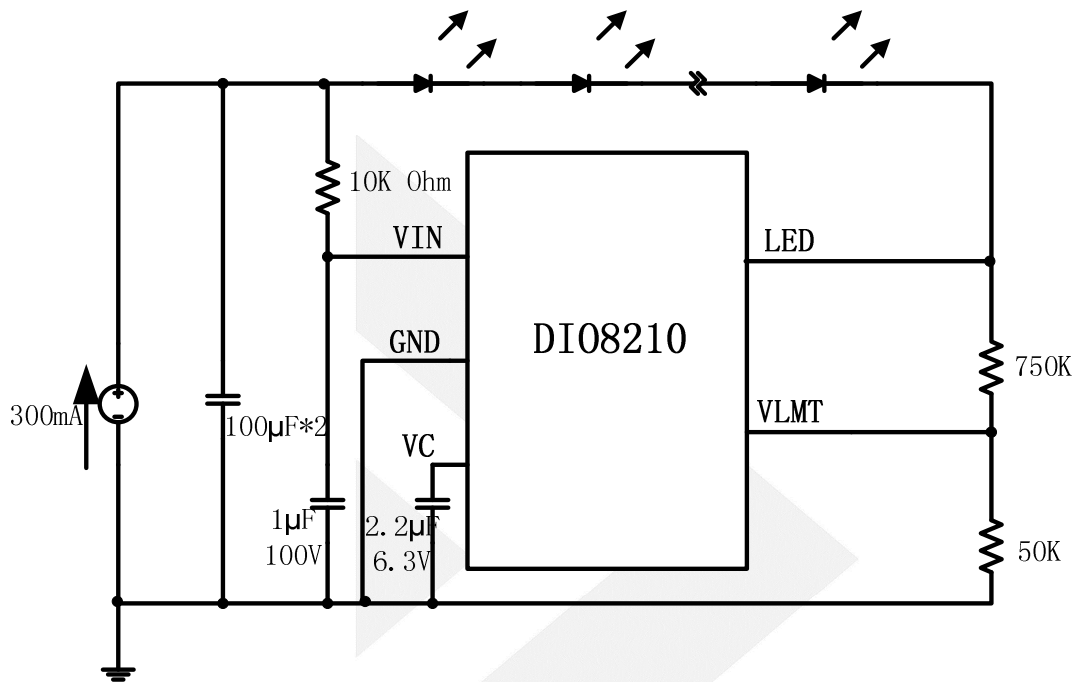

dioo



DIO8210

Adaptive 100/120Hz Current Ripple Remover, Max Input Current \leq 350mA

CONTACT US

Dioo is a professional design and sales corporation for high-quality and performance analog semiconductors. The company focuses on industry markets, such as, cell phone, handheld products, laptop, and medical equipment and so on. Dioo's product families include analog signal processing and amplifying, LED drivers and charger IC. Go to <http://www.dioo.com> for a complete list of Dioo product families.

For additional product information, or full datasheet, please contact with our Sales Department or Representatives.

dioo