

# DIO5180

## 2MHz, 1.5A Flash LED Driver

### Features

- Dual Flash LED Outputs
- Drive Up to Total 1.5A or 0.75A per Channel
- Up to 90% Efficiency
- Integrated 2MHz Step-Up Converter
- 3V to 5V Operation Voltage Range
- Very Small Inductor: 1.0 $\mu$ H
- Independent Flash Mode Enable and Movie/Torch Mode Enable Pins
- Flash Mode or Movie/Torch Mode Dimming via PWM Control
- One Resistor Sets Flash Mode LED Current
- One Resistor Sets Movie/Torch Mode LED Current
- Integrated Thermal Regulation Control
- 10kHz to 200kHz PWM Dimming Frequency
- 600ms Flash Timer Control
- 330k $\Omega$  Pull-Down Resistor on ENM and ENF Pins
- LED Open or Short Protection
- Output Over-Voltage Protection
- Cycle-by-Cycle Inductor Current Limit
- 0.1 $\mu$ A Shutdown Current
- Available in Green DFN-3 $\times$ 2-14L Package
- -40 $^{\circ}$ C to +85 $^{\circ}$ C Operating Temperature Range

### Typical Applications

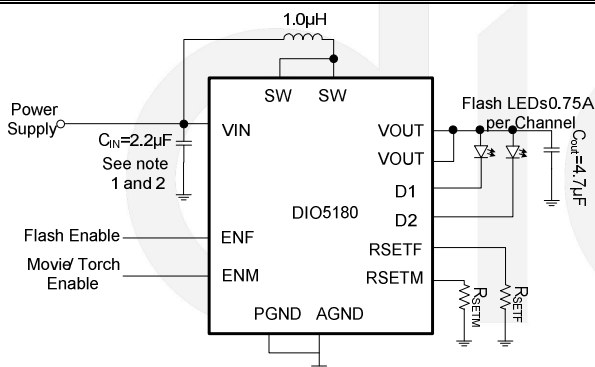

#### Note:

- 1: The decoupling capacitor  $C_{IN}$  and  $C_{OUT}$  at the input and output should be placed as close as possible to VIN pin and VOUT pin.
- 2: The power supply is recommended to be routed to VIN pin first with capacitor closely placed, then routed to inductors and then to SW pin.

### Descriptions

DIO5180 is a Boost-architecture high power flash LED driver, ideally for smart phone camera modules or digital still camera modules. The internal DC/DC switch works at 2MHz and needs few peripheral components, fitting for portable photo flash solution.

DIO5180 has independent Flash mode and Movie/Torch mode enable pins. Flash mode is usually used with 600ms timer control to generate a high intensity flash. The Flash mode and Movie/Torch mode LED current is programmed by external resistors respectively, making the flash LED solution simple to control. If both enable pins are at logic high, the LED current will be programmed by the Movie/Torch mode setting resistor.

The two LED output sinks can be shorted together externally for higher power single flash LEDs, up to 1.5A continuous LED current. Thermal regulation is integrated in Flash mode to limit the IC's temperature and continuously provide the maximum allowed output current.

DIO5180 has many protection features, including cycle-by-cycle input current limit protection, output over-voltage protection, LED fault (open or short) protection and thermal shutdown protection. The leakage current in shutdown is 0.1 $\mu$ A. DIO5180 is available in Green DFN-3 $\times$ 2-14L package. It operates over an ambient temperature range of -40 $^{\circ}$ C to +85 $^{\circ}$ C.

### Applications

- Single Cell Li-Battery Powered Products
- Portable Audio Players
- Cellular Phones
- Personal Medical Products

## Ordering Information

Order Part Number	Top Marking		T <sub>A</sub>	Package	
DIO5180CD14	D5180	Green	-40 to +85°C	DFN-3×2-14L	Tape & Reel, 3000

## Pin Assignments

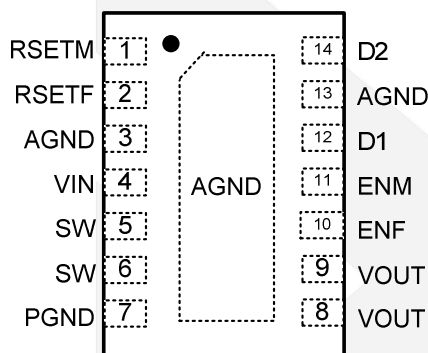

Figure 1 Pin Assignment (Top View)

## Pin Definitions

PIN	Pin Name	Description
1	RSETM	Movie and Torch Mode Current Setting Pin
2	RSETF	Flash Mode Current Setting Pin
3,13	AGND	Analog Ground Pin
4	VIN	Input Supply Pin for the IC
5,6	SW	Switching Node of the Step-Up Converter
7	PGND	Power Ground Pin.
8,9	VOUT	Output Voltage Pin.
10	ENF	Flash Mode Enable Pin. This pin has an internal 330k pull-down resistor to AGND.
11	ENM	Movie/Torch Mode Enable Pin. This pin has an internal 330k pull-down resistor to AGND.
12	D1	Regulated Output Sink Current. Up to 0.75A current. D1 and D2 pins can be connected together to sink 1.5A combined. Can not be floating in any case.
14	D2	
Exposed pad	AGND	Connected to ground for electrical and thermal usage. Exposed pad is Pad internally connected to analog ground pin.



## DIO5180

2MHZ, 1.5A Flash LED Driver

### Absolute Maximum Ratings

Stresses beyond those listed under “Absolute Maximum Rating” may cause permanent damage to the device. These are stress ratings only and functional operation of the device at these or any other condition beyond those indicated in the operational sections of the specifications is not implied. Exposure to absolute maximum rating conditions for extended periods may affect device reliability.

Parameter	Rating	Unit
VIN, VOUT, D1 and D2 voltage	-0.3 to 6	V
ENF, ENM, RSETF, RSETM	-0.3 to VIN+0.3	V
SW voltage	-0.3 to 6.5	V
Junction Temperature	150	°C
Storage Temperature	-65 to 150	°C
Lead Temperature (soldering, 10s)	260	°C
ESD (HBM)	5000	V
ESD (MM)	200	V

### Recommend Operating Conditions

The Recommended Operating Conditions table defines the conditions for actual device operation. Recommended Operating conditions are specified to ensure optimal performance to the datasheet specifications. DIOO does not Recommend exceeding them or designing to Absolute Maximum Ratings.

Parameter	Rating	Unit
Input Supply Voltage	3 to 5	V
Operating Temperature Range	-40 to 85	°C





# DIO5180

2MHz, 1.5A Flash LED Driver

## Electrical Characteristics

( $V_{IN} = V_{EN} = 3.6V$ , typical values at  $+25^{\circ}C$ , unless otherwise noted.)

Parameter	Symbol	Conditions	Min	Typ	Max	Unit
<b>IC Supply</b>						
Input Voltage Range	$V_{IN}$		3		5	V
Under-Voltage Lockout Threshold	UVLO	Rising edge		2.4		V
Under-Voltage Lockout Hysteresis	$V_{HYS}$			0.23		V
Supply Current	$I_Q$	Not switching		350		$\mu A$
Supply Current in Shutdown	$I_{SHDN}$	ENF=ENM=GND		0.1		$\mu A$
<b>Step-up Converter</b>						
Oscillator Frequency	$f_S$			2		MHz
Internal Over-Voltage Threshold of OUT	$V_{OVP}$			5.3		V
Flash Mode Soft-Start Time	$t_S$			200		$\mu s$
<b>Current Sink</b>						
Total Output Current, Movie/Torch Mode	$I_D$	ENM=HIGH, $R_{SETM}=75k\Omega$ , D1+D2, $T_A=25^{\circ}C$	170	200	230	mA
Total Output Current, Flash Mode		ENF=HIGH, ENM=GND, $R_{SETF}=12k\Omega$ , D1+D2, $T_A=25^{\circ}C$	1.275	1.5	1.725	A
Output Current Matching		100mA each channel, $T_A = 25^{\circ}C$		2	8	%
		750mA each channel, $T_A = 25^{\circ}C$		1	5	%
LED Short Checking Current	$I_{SHORT}$			2.5		mA
<b>Control</b>						
ENF, ENM Pin Logic Low Threshold	$V_{IL}$				0.4	V
ENF, ENM Pin Logic High Threshold	$V_{IH}$		1.5			V
ENF Internal Pull-Down Resistance	$R_{PD(ENF)}$			330		k $\Omega$
ENM Internal Pull-Down Resistance	$R_{PD(ENM)}$			330		k $\Omega$
Junction Thermal Shutdown Threshold				145		$^{\circ}C$
Junction Thermal Shutdown Hysteresis				17		$^{\circ}C$
<b>Delay Time To Shutdown Status In Movie/Torch Mode (For PWM Dimming LED Current)</b>						
Delay Time	$t_D$			3		ms
<b>Flash Timer</b>						
Hardware Flash Timer	$t_{TIME}$			600		ms

Specifications subject to changes without notice.

## Typical Application

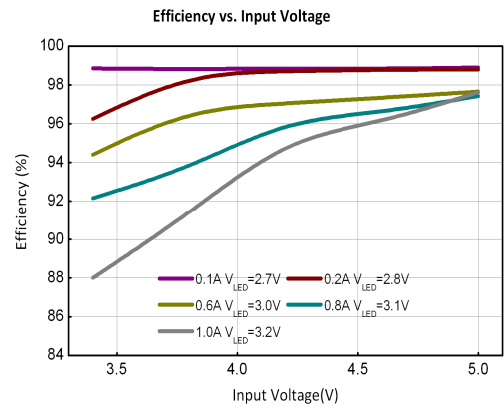
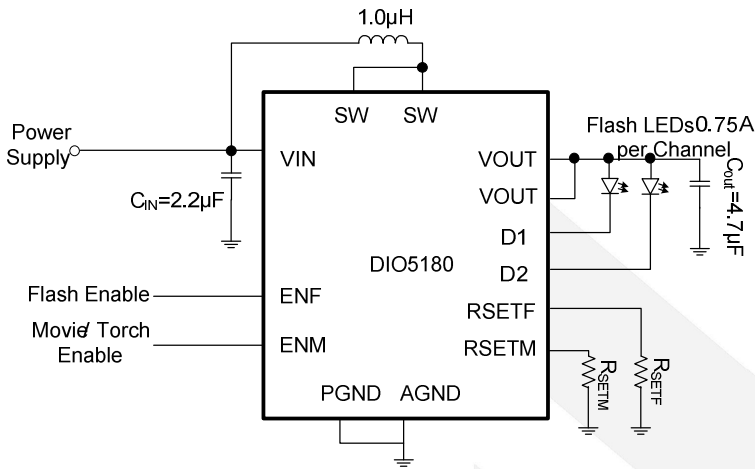

## Functional Block Diagram

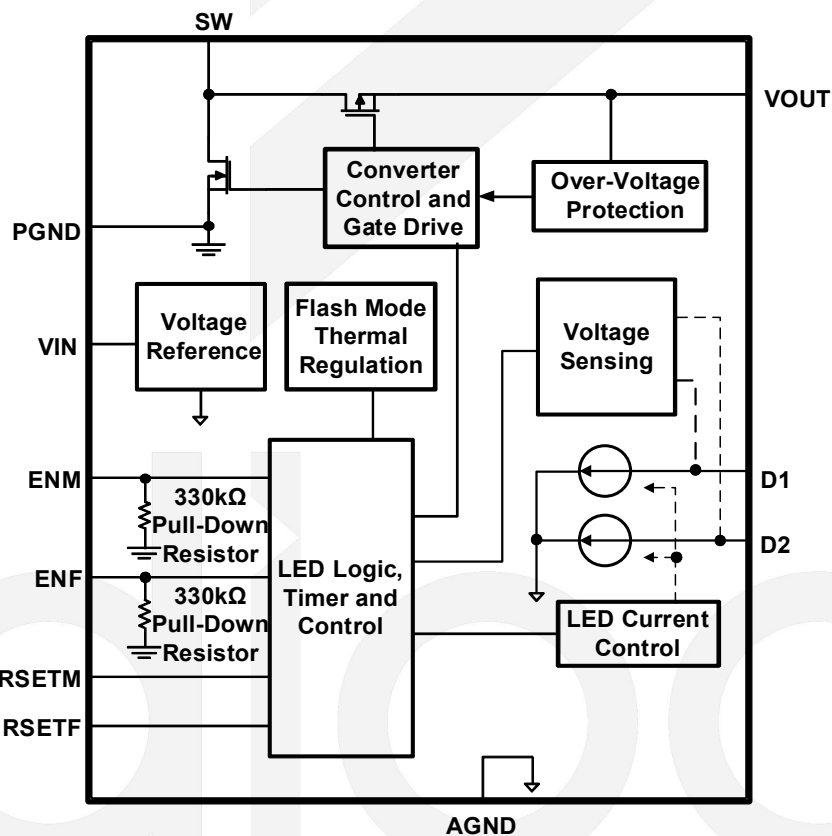

### State Diagram

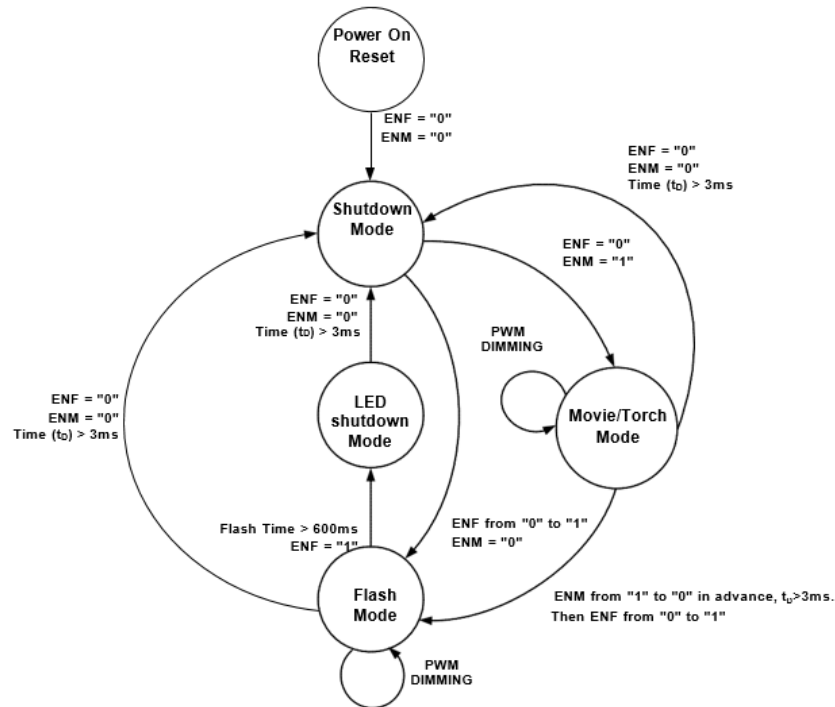

### Application Information

The DIO5180 is a very high switching frequency step-up (boost) flash LED driver. Two current regulating devices are integrated to drive up to 2 flash LEDs.

The voltage step-up is accomplished by a boost topology, using an inductor-based DC/DC switching converter, in which the inductor serves as an energy storage device. By integrating optimized power MOSFETs, the DIO5180 internal switching frequency is 2MHz while still maintaining high power efficiency. Unlike a traditional DC/DC boost converter with a fixed output voltage, the DIO5180 dynamically changes its output voltage depending on the flash LED forward voltage and current. The use of unique control schemes maintains accurate current regulation in each of the two current sinks while leaving the output voltage at a minimum, increasing the overall conversion efficiency. The internal step-up converter boosts the output voltage high enough to drive the LEDs with the highest forward voltage. The two current sinks can be shorted together to drive a higher current single flash LED, sinking up to 1.5A combined.

The control interface is designed for maximum design flexibility and compatibility with various types of system controls. When the ENF is pulled high while the ENM is low, the LED current will be ramped up to the Flash mode current level which is programmed by  $R_{SETF}$  resistor. When ENM is pulled high while the ENF is low, the LED current will be ramped up to the Movie/Torch mode current level which is programmed by  $R_{SETM}$  resistor. However, if both ENM and ENF are high, the LED current will be set to Movie/Torch mode current. The driver IC and the flash LEDs will be shutdown when both ENF and ENM are at logic low.

#### Flash Mode LED Current

D1 and D2 Flash mode LED current can be programmed up to a maximum total current of 1.5A or up to 0.75A per channel. The sink current in D1 and D2 are internally matched in the DIO5180. The Flash mode current in each channel is set by the  $R_{SETF}$  resistor. For the desired Flash mode current in each output, the resistor value can be



## DIO5180

calculated using the following equation:

$$I_{\text{FLASH (D1)}} = I_{\text{FLASH (D2)}} = 9000/R_{\text{SETF}}$$

For DIO5180, A flash event is initiated by asserting the ENF pin while ENM is at logic low level. A flash event is automatically terminated when ENF is deasserted or when ENM is asserted. For additional flexibility, a lower Flash mode current than the value calculated above can be realized by applying a PWM dimming signal at ENF pin while ENM is held low. The average Flash mode current will be proportional to the PWM duty ratio. The range of PWM dimming frequency is from 10kHz to 200kHz.

Automatic thermal regulation control is active when DIO5180 is in Flash mode. If Flash mode is enabled and the flash current is set to a high current value, the temperature of the IC can increase quickly. Once the IC's temperature goes above 100°C, the two sinks' currents will be automatically decreased according to the thermal regulation control loop. This can prevent the IC from triggering thermal shutdown and causing the LEDs to flicker. Depending on the thermal layout of the PCB and the Flash mode current setting, the DIO5180 sink current can be lower than the programmed value due to the thermal regulation protection feature.

### LED Short Protection

When the DIO5180 is enabled, there is a 2.5mA (typical) LED sensing current through each current sink. It is used to detect whether either LED is shorted by generating a voltage drop through each LED. The IC internally compares the voltage difference between  $V_{\text{OUT}}$  and each sink node (D1 and D2). If this difference is below a preset threshold, the IC will treat the respective LED as shorted and disable its Flash/Movie mode current through this LED channel. However, the 2.5mA sensing current will be kept to generate the LED's voltage drop. Because some normal flash LEDs may have larger than desired leakage current (up to hundreds of micro-amps) even it's not fully turned on, this 2.5mA sensing current can guarantee that a properly functioning LED will not mistakenly be treated as a shorted LED. If the short circuit is removed during operation, the channel will automatically recover to the programmed current setting.

### LED Open Protection

In case of LED open, the open channel will control the loop first so that  $V_{\text{OUT}}$  will reach OVP (approximately 5.3V), and then DIO5180 will automatically detect which channel's LED is open and disable that channel. From that point, the other channel with properly operating LED will control the loop and  $V_{\text{OUT}}$  will be regulated down to a normal operating voltage. This protection feature avoids unnecessary power consumption in the current sink by regulating the output voltage at the lowest level possible to maintain regulation for the active channel. Not only does this protect from open LEDs failures, but also allows only single flash LED operation with the unused channel floating or open. Open-circuit LED fault protection is reset when the IC is powered down and up again.

### Movie/Torch Mode LED Current

D1 and D2 Movie/Torch mode LED current can be programmed up to a maximum total current of 400mA or up to 200mA per channel. Just as in Flash mode operation, the output currents in D1 and D2 are internally matched. The Movie/Torch mode current in each channel is set by the  $R_{\text{SETM}}$  resistor. For the desired Movie/Torch mode current in each output, the resistor value can be calculated using the following equation:



## DIO5180

$$I_{MOVIE(D1)} = I_{MOVIE(D2)} = 7500/R_{SETM}$$

A Movie/Torch mode event is initiated by asserting the ENM pin. For additional flexibility, a lower Movie/Torch mode current than the value calculated above can be realized by applying a PWM dimming signal at ENM pin while ENF is held low. The average Movie/Torch mode current will be proportional to the PWM duty ratio.

### Inductor Selection

The DIO5180 is designed to use a 1.0µH to 2.2µH inductor. To prevent core saturation, ensure that the inductor-saturation current rating exceeds the peak inductor current for the application. The worst-case peak inductor current can be calculated with the following formula:

$$I_{PEAK(L)} = \frac{V_{O(MAX)} \times I_{LED(MAX)}}{0.8 \times V_{IN(MIN)}} + \frac{V_{IN(MIN)} \times t_{ON(MAX)}}{2 \times L}$$

Where 0.8 is the estimated efficiency of 80%. For example, for a 1.5A total (or 0.75A per channel) LED current, the peak inductor current for a 1.0µH inductor could be as high as (estimated 50% as the maximum duty ratio at the minimum input voltage, maximum LED forward voltage and maximum load current conditions):

$$I_{PEAK(L)} = \frac{4V \times 1.5A}{0.8 \times 3.5V} + \frac{3.5V \times 0.25}{2 \times 1} = 2.6A$$

If the inductor value is smaller, the inductor peak current will increase. To maintain stable operations for the boost converter, the inductor peak current must be less than both the DIO5180 current limit threshold (2.9A TYP) and the inductor saturation current rating. Manufacturer's specifications of inductors list both the inductor DC current rating, which is a thermal limitation, and peak inductor current rating, which is determined by the saturation characteristics. Measurements at full load and high ambient temperature should be performed to ensure that the inductor does not saturate or overheat due to its parasitic resistance. Bench measurements are recommended to confirm actual inductor peak current  $I_{PEAK}$  and to ensure that the inductor does not saturate at maximum LED current and minimum input supply voltage.

### Recommend Power Inductor and Parameters

Manufacturer	P/N	Inductance	DCR	Isat(A)		Irms(A)		Dimension
		µH	Ω	MAX	TPY	MAX	TYP	mm
Sunlord	WPN201610H1R0MT	1.0±20%	0.075	3.35	3.85	2.05	2.35	2.0*1.6*1.0
Sunlord	WPN252010H1R0MT	1.0±20%	0.076	3.1	3.5	2.5	2.9	2.5*2.0*1.0

### Capacitor Selection

For good input voltage filtering low ESR ceramic capacitors are recommended. At least a 2.2µF input capacitor is recommended for high current flash LEDs to improve transient behavior of the regulator and EMI behavior of the total power supply circuit. The input capacitor should be placed as close as possible to the input pin and the PGND pin of the DIO5180. The output capacitance required depends on the required LED current. A 2.2µF or 4.7µF ceramic capacitor works well in most situations.



## Layout Guidelines

It is very important to PCB layout, especially to high switching transition and high current converter. Careful PCB layout is required, or the regulator maybe happen unstable problem, as well as EMI problem. Therefore, wide and short traces will be considered for the main switching current paths and ground. The below guide lines will be recommended.

1. Input capacitor, output capacitor, inductor and flash LED should be placed as possible as close to the DIO5180 chip.
2. Input and output capacitors ground should be placed as possible as close to GND PIN, and wide traces will be recommended as well.
3. Inductor should be placed as possible as close to SW PIN, and wide traced will be recommended as well.
4. Flash LED should be placed as possible as close to D1/D2, and wide traced will be recommended as well.
5. Analog trace, such as RSETM and RSETF, should be routed far away from SW areas.
6. Ground nodes should be placed as possible as close to GND PIN.

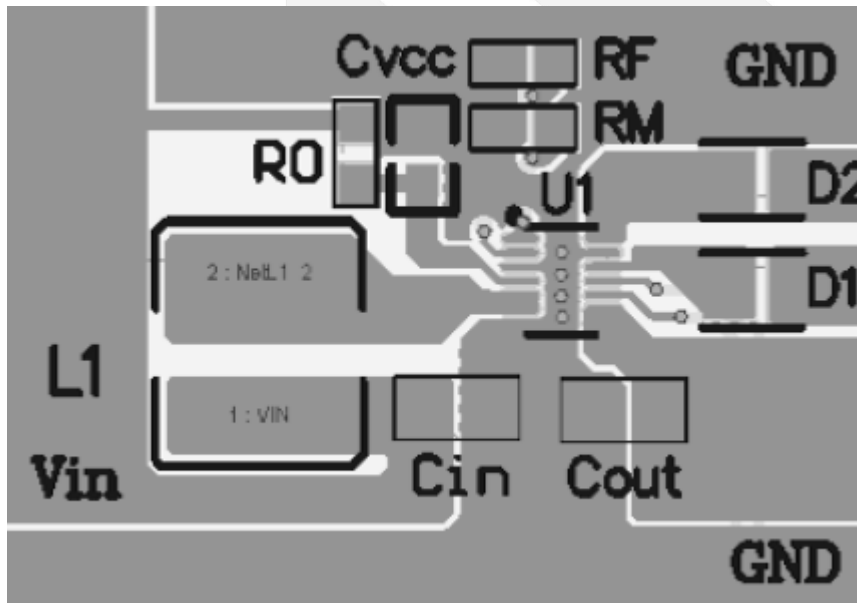



# DIO5180

2MHz, 1.5A Flash LED Driver

## Typical Performance Characteristics

Unless otherwise noted,  $T_A=25^\circ\text{C}$ ,  $V_{IN}=3.6\text{V}$ ,  $C_{IN}=2.2\mu\text{F}$ ,  $C_{OUT}=4.7\mu\text{F}$ ,  $R_{SETM}=75\text{Kohm}$ ,  $R_{SETF}=12\text{Kohm}$ .

### Flash mode

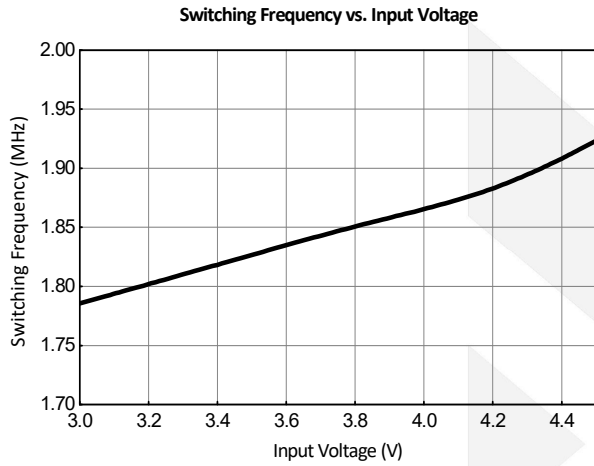

### Torch mode & Flash mode

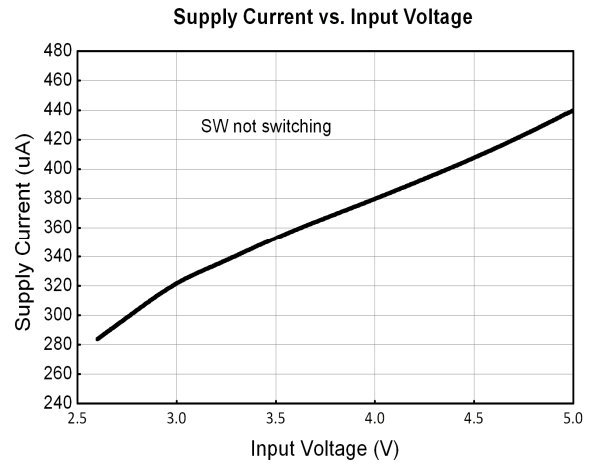

### Torch mode

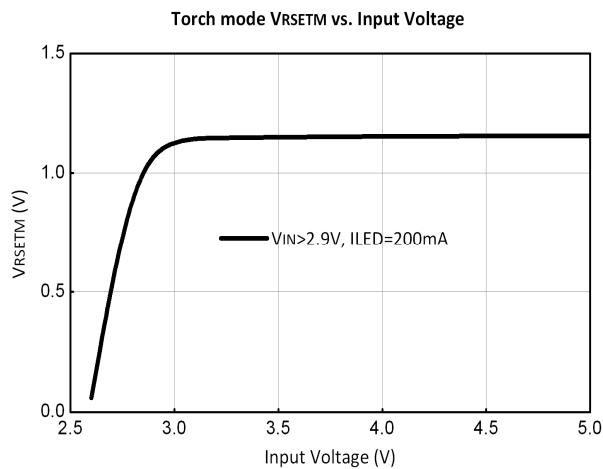

### Torch mode

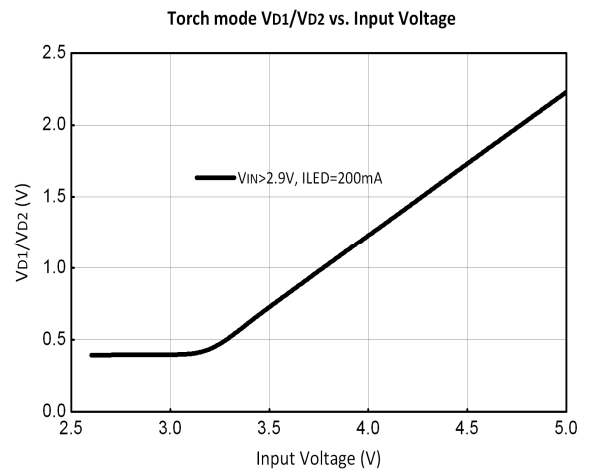

### Torch EN Turn On

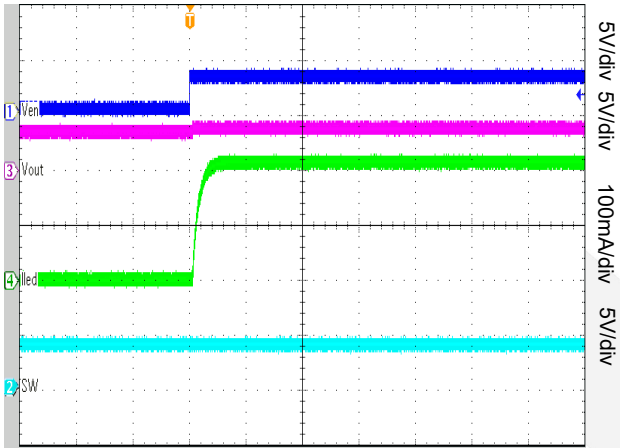

Time (4ms/div)

### Torch EN Turn Off

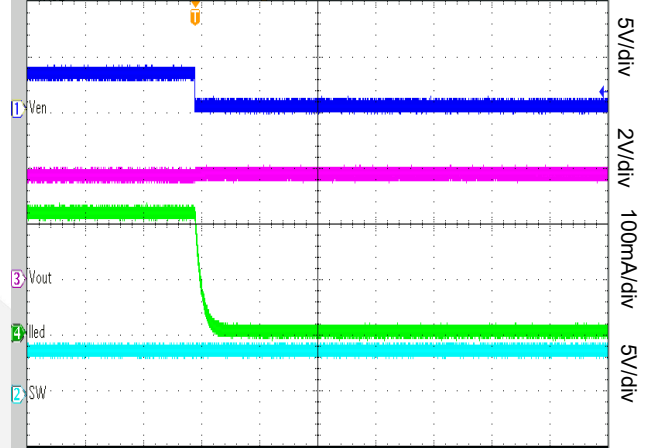

Time (4ms/div)

### 1.5A Flash Operation

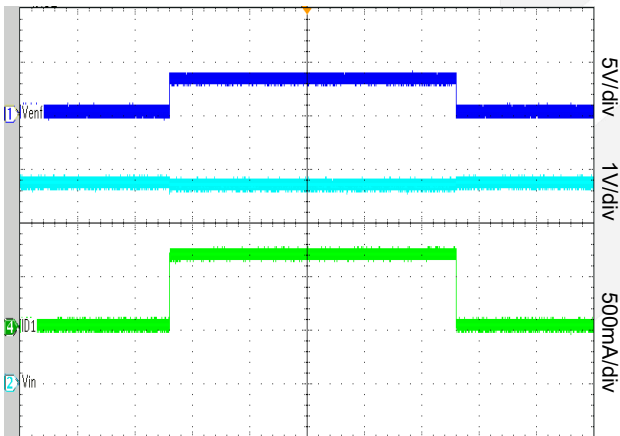

Time (100ms/div)

### Flash EN Turn On

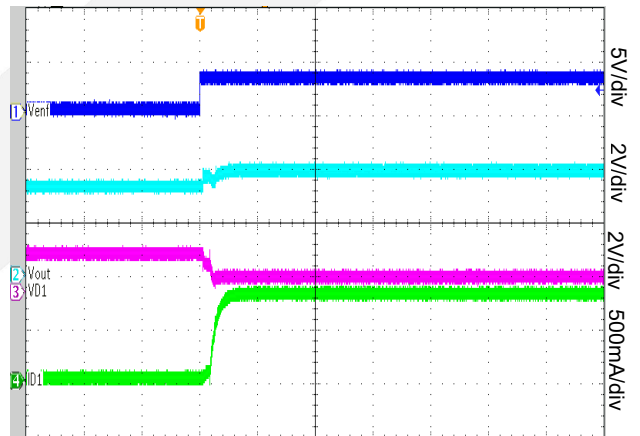

Time (2ms/div)





DIO5180

2MHZ, 1.5A Flash LED Driver

## CONTACT US

Dioo is a professional design and sales corporation for high-quality and performance analog semiconductors. The company focuses on industry markets, such as, cell phone, handheld products, laptop, and medical equipment and so on. Dioo's product families include analog signal processing and amplifying, LED drivers and charger IC. Go to <http://www.dioo.com> for a complete list of Dioo product families.

For additional product information, or full datasheet, please contact with our Sales Department or Representatives.

