

DIO2774

4-Channel Video Amplifier with One SD and Three HD 8th Order Filters with 6dB Gain

Features

- One SD Video Amplifier for CVBS Video
- Three HD Video Amplifiers
- Transparent Input Clamping
- Fixed 6dB Gain
- AC or DC Coupled Inputs
- AC or DC Coupled Outputs
- Operates from 3.135V to 5.25V
- Single Power Supply
- RoHS or Green TSSOP-14 Package
- HBM ESD protection:
Output to GND: 8kV
All others to GND: 7kV

Applications

- DVD Players
- Video Amplifiers
- Cable set-top boxes
- Personal Video Recorders
- Communications Devices
- Video on Demand

Descriptions

DIO2774 is a low power, 4 channels video amplifier with one standard definition (SD) for CVBS video and three high-definition (HD) filter channels. The CVBS filter features 8th order filter and the HD channels feature 8th order filters.

All CVBS and HD filters are used as digital-to-analog converter (DAC) reconstruction filters or as analog-to-digital converter (ADC) filters. The HD filters can be bypassed to support 1080p60 video or up to super extended graphics array (SXGA) RGB video.

Either ac or dc-coupled inputs can configure the device. And the device has flexible input coupling capabilities also.

Block Diagram

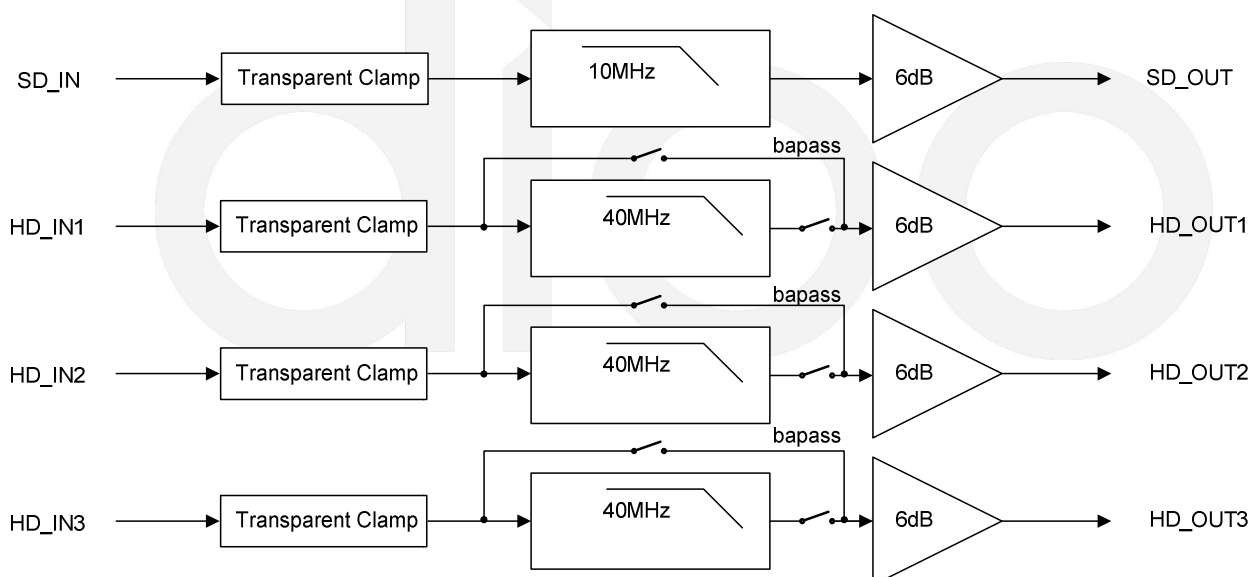



DIO2774

4-Channel Video Amplifier with One SD and Three HD 8th Order Filters with 6-dB Gain

Ordering Information

Order Part Number	Top Marking		T _A	Package	
DIO2774CT14	DIO2774	RoHS or Green	-40 to +85°C	TSSOP-14	Tape & Reel, 2500

Pin Assignments

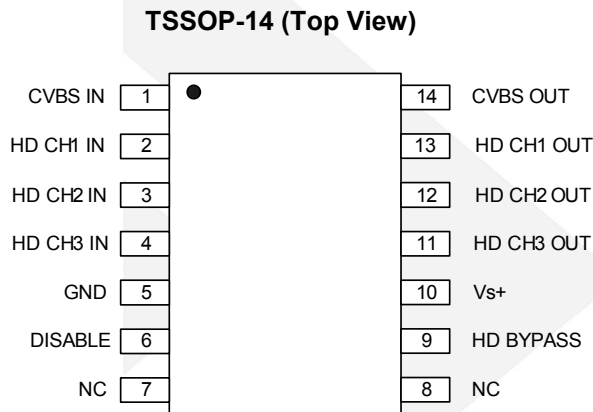

Figure 1 Pin Assignment

Pin Description

Pin	Name	Type	Description
1	CVBS IN	Input	CVBS filter video input
2	HD CH1 IN	Input	HD channel 1 video input
3	HD CH2 IN	Input	HD channel 2 video input
4	HD CH3 IN	Input	HD channel 3 video input
5	GND	Ground	Ground pin
6	DISABLE	Input	Disable pin. Logic high disables the device, logic low enables. Defaults to logic low (enabled) if left floating.
7,8	NC	-	Not connect
9	HD BYPASS	Input	Internal HD filter bypass. Logic high bypasses the internal HD low-pass filters, logic low uses the HD internal filters. Defaults to logic '0' (filter mode) if left floating.
10	Vs+	Input	Positive power-supply pin, connect to +3 V to +5 V
11	HD CH3 OUT	Output	HD channel 3 video output
12	HD CH2 OUT	Output	HD channel 2 video output
13	HD CH1 OUT	Output	HD channel 1 video output
14	CVBS OUT	Output	CVBS filter video output

Logical Table

The logic input pins defaults to a logic '0' condition when left floating.

Pin Name	Input / Output	Default Logic State	Logic States	Description
Disable	Input	0	0	All channels enabled
		0	1	All channels disabled
HD Bypass	Input	0	0	HD channels use 8th-order low-pass filters
		0	1	HD channels bypass low-pass filters

Absolute Maximum Ratings

Stresses beyond those listed under "Absolute Maximum Rating" may cause permanent damage to the device. These are stress ratings only and functional operation of the device at these or any other condition beyond those indicated in the operational sections of the specifications is not implied. Exposure to absolute maximum rating conditions for extended periods may affect device reliability.

Parameter		Rating	Unit
Supply Voltage		0 to 6.0	V
Input Voltage		-0.3 to $V_{CC}+0.3$	V
Storage Temperature Range		-65 to 150	°C
Junction Temperature		150	°C
Lead Temperature Range		260	°C
TSSOP-14 θ_{Jc}		35	°C/W
TSSOP-14 θ_{JA}		125	°C/W
ESD	HBM (Output to GND)	8	kV
	HBM (All others to GND)	7	kV

Recommended Operating Conditions

The Recommended Operating Conditions table defines the conditions for actual device operation to ensure optimal performance to the datasheet specifications. DIOO does not recommend exceeding them or designing to Absolute Maximum Ratings.

Parameter	Rating	Unit
Supply Voltage	3.135 to 5.25	V
Operating Temperature Range	-40 to 85	°C



DIO2774

4-Channel Video Amplifier with One SD and Three HD 8th Order Filters with 6-dB Gain

Electrical Characteristics

Typical value: $T_A = 25^\circ\text{C}$, $V_{CC}=5\text{V}$, $R_{SOURCE}=37.5\Omega$, $R_L=150\Omega$ loads; all inputs are AC couple with $0.1\mu\text{F}$; all outputs are AC coupled with $220\mu\text{F}$; unless otherwise specified.

Symbol	Parameter	Conditions	Min.	Typ.	Max.	Unit
DC ELECTRICAL CHARACTERISTICS						
I_{CC}	Supply Current	Bypass=0.		80		mA
		Bypass=1.		50		
V_{IN}	Input Common Mode Voltage Range		GND		1.4	V_{PP}
V_{OS}	Output Offset Voltage	$V_{IN}=0\text{V}$, no load, Bypass=0.		250		mV
		$V_{IN}=0\text{V}$, no load, Bypass=1.		330		
PSRR	Power Supply Rejection			50		dB
HIGH DEFINITION AC PERFORMANCE						
AV	Channel Gain		5.8	6.0	6.2	dB
BW	Band Width	$\pm 0.5\text{dB}$, $R_{SOURCE}=75\Omega$		32		MHz
		-1dB, $R_{SOURCE}=75\Omega$		35		
		-3dB, $R_{SOURCE}=75\Omega$, Bypass=0		40		
		-3dB, $R_{SOURCE}=75\Omega$, Bypass=1		110		
AR	Attenuation	$f=30\text{MHz}$, $R_{SOURCE}=75\Omega$		-0.1		dB
		$f=37.125\text{MHz}$, $R_{SOURCE}=75\Omega$		-1.7		
		$f=44.25\text{MHz}$, $R_{SOURCE}=75\Omega$		-6		
		$f=74.25\text{MHz}$, $R_{SOURCE}=75\Omega$		-30		
THD	Output Distortion	$V_{OUT}=1.4V_{PP}$, $f=10\text{MHz}$		0.6		%
		$V_{OUT}=1.4V_{PP}$, $f=20\text{MHz}$		0.8		
X_{TALK}	Crosstalk	$f=1\text{MHz}$, $V_{IN}=1.4V_{PP}$		-75		dB
SNR	Signal to Noise Ratio	100kHz to 30MHz, 100% White Signal		65		dB
	Group Delay	100kHz to 30MHz, Bypass=0		6		ns
		100kHz to 30MHz, Bypass=1		1		
	Propagation Delay	Input to Output		20		ns
SR	Slew Rate	2V Output 80% to 20%		90		$\text{V}/\mu\text{s}$
STANDARD DEFINITION AC PERFORMANCE						
AV	Channel Gain		5.8	6.0	6.2	dB

BW	Bandwidth	-1dB		8.0		MHz
		-3dB		10		
AR	Attenuation	f=27MHz		-53		dB
DG	Differential Gain			0.6		%
DP	Differential Phase			1.2		°
THD	Output Distortion	f=4MHz		1.5		%
X _{TALK}	Crosstalk	f=1MHz		-85		dB
SNR	Signal to Noise Ratio			70		dB
t _{PD}	Propagation Delay			80		ns
	Group Delay	f=400kHz, 6.5MHz		10		ns
CLG _{SD}	Chroma Luma Gain	f=3.58MHz ref to SD in at 400kHz		100		%
CLD _{SD}	Chroma Luma Delay	f=3.58MHz ref to SD in at 400kHz		5.5		ns
LOGIC CHARACTERISTICS						
V _{IH}	High-level, input voltage	VCC=5.0V, Disabled or HD bypass engaged	2.1			V
		VCC=3.3V, Disabled or HD bypass engaged	1.6			V
V _{IL}	Low-level, input voltage	VCC=5.0V, Enabled or HD bypass disengaged			0.9	V
		VCC=3.3V, Enabled or HD bypass disengaged			0.6	V
I _{IH}	High-level, input current	VCC=5.0V, Applied voltage = 5V		1.4		μA
		VCC=3.3V, Applied voltage = 3.3V		0.6		μA
I _{IL}	Low-level, input current	Applied voltage = 0 V		0		μA
TSD				145		°C
	Hysteresis			15		°C

Notes: SNR=20 • log (714mV / rms noise).

Specifications subject to change without notice.

Typical Performance Characteristics

Typical value: $T_A = 25^\circ\text{C}$, $V_{CC} = 5\text{V}$, $R_{SOURCE} = 37.5\Omega$, $R_L = 150\Omega$ loads; all inputs are AC couple with $0.1\mu\text{F}$; all outputs are AC coupled with $220\mu\text{F}$; unless otherwise specified.

ICC vs. VCC

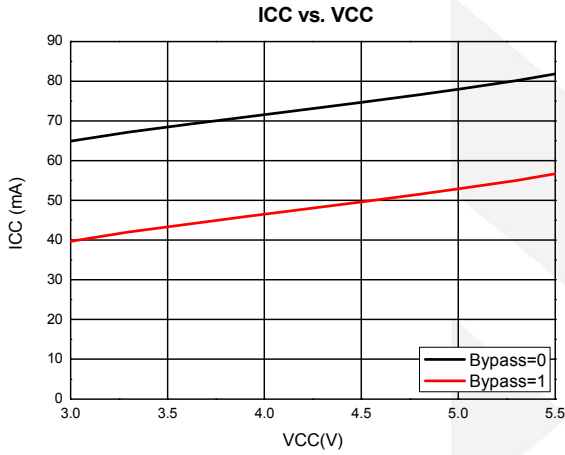

ICC vs. Temperature

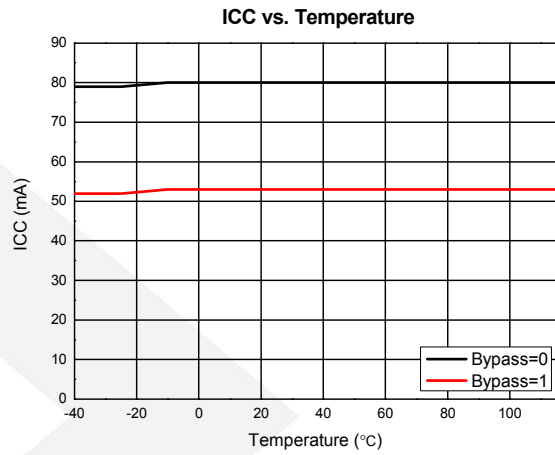

CVBS BW vs. Frequency

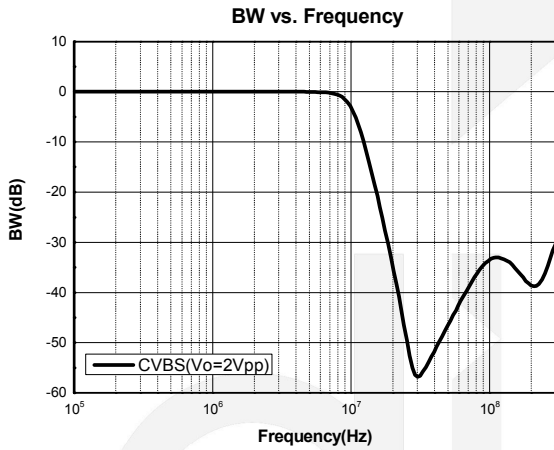

HD BW vs. Frequency

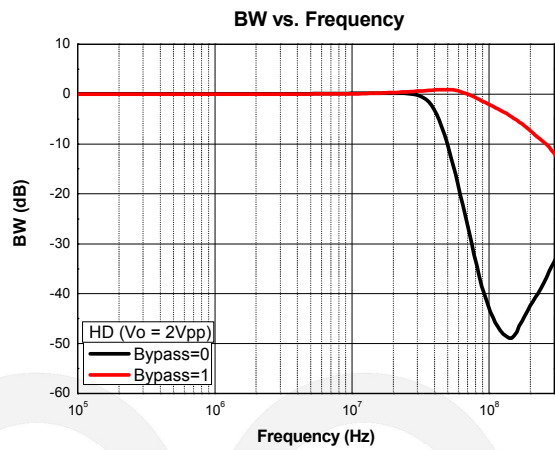

Application Circuit

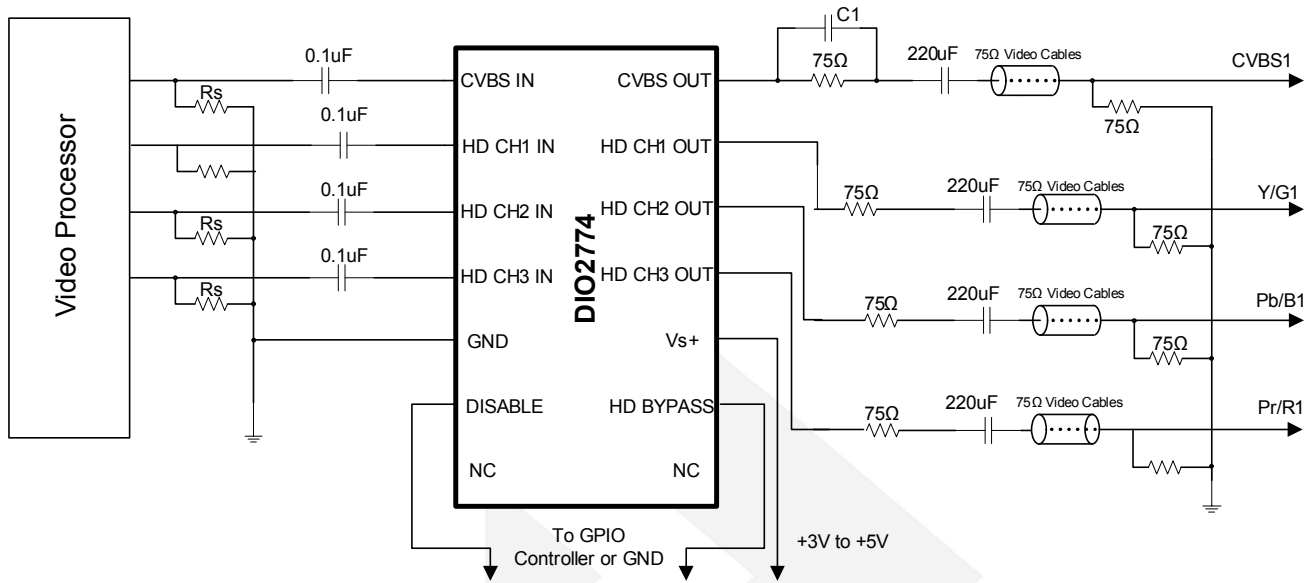

Figure 2 Input and Output AC-Coupling Application

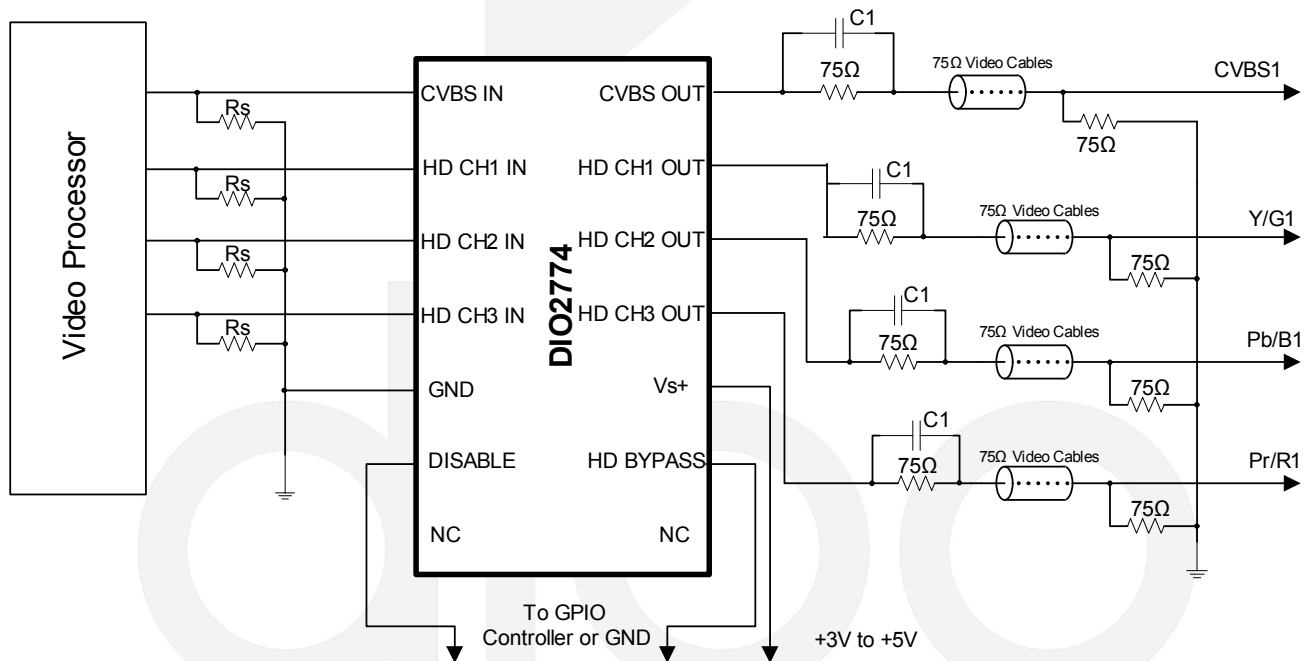

Figure 3 Input and Output DC-Coupling Application

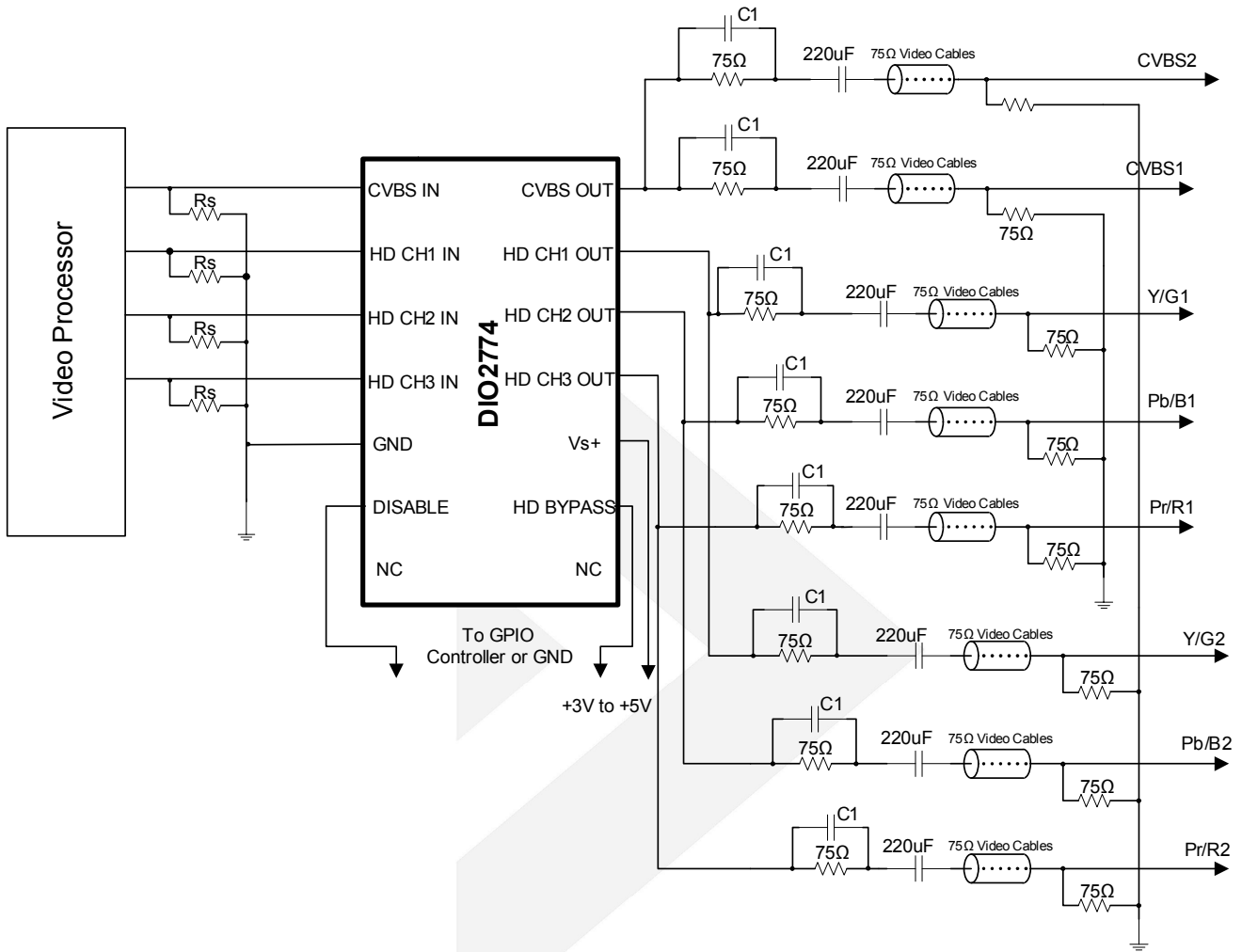

Figure 4 Input DC-Coupling Application and Output AC-Coupling with Double Load

Note: The value of C_1 is recommended 2 to 4pF



CONTACT US

Dioo is a professional design and sales corporation for high-quality and performance analog semiconductors. The company focuses on industry markets, such as, cell phone, handheld products, laptop, and medical equipment and so on. Dioo's product families include analog signal processing and amplifying, LED drivers and charger IC. Go to <http://www.dioo.com> for a complete list of Dioo product families.

For additional product information, or full datasheet, please contact with our Sales Department or Representatives.

