

# DIO2684

## One Channel SD and Three Channel 1080i High Definition Video Filter

### Features

- One CVBS channel with 6th-order, 9MHz filter
- Three channels with per channel a 6th-order, 37MHz filter
- Transparent Input Clamping
- Fixed 6dB Gain
- AC or DC Coupled Inputs
- AC or DC Coupled Outputs
- Operates from 3.135V to 5.25V Single Power Supply
- RoHS or Green EP-MSOP-10 Package
- 8kV ESD protection

### Applications

- DVD Players
- Video Amplifiers
- Cable set-top boxes
- Personal Video Recorders
- Communications Devices
- Video on Demand

### Block Diagram

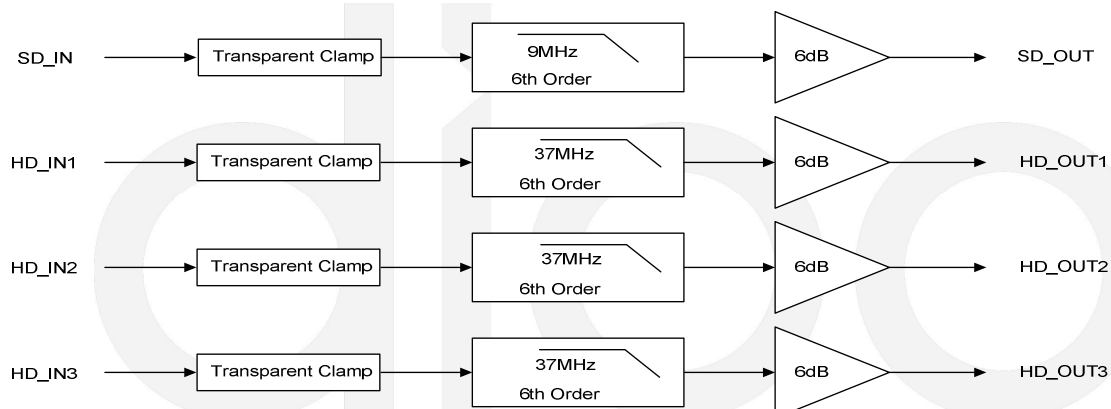

### Ordering Information

Order Part Number	Top Marking		T <sub>A</sub>	Package	
DIO2684XM10	DIO2684	Green	-40 to +85°C	EP-MSOP-10	Tape & Reel, 3000

### Descriptions

DIO2684 is a low voltage, four channels video amplifier with integrated 6dB reconstruction filter and input clamps. In fact, DIO2684 integrates a single CVBS (SD) video driver plus a triple 1080i HD video driver. DIO2684 can improve image quality compared to the passive LC filters.

All channels can be directly driven by a DC-coupled or an AC-coupled signal. Internal diode-like clamps and bias circuitry may be used if AC-coupled inputs are required. The output in DIO2684 can also drive AC or DC coupled single (150Ω) or dual (75Ω) loads. The DC coupling capacitors can be removed.

### Pin Assignments

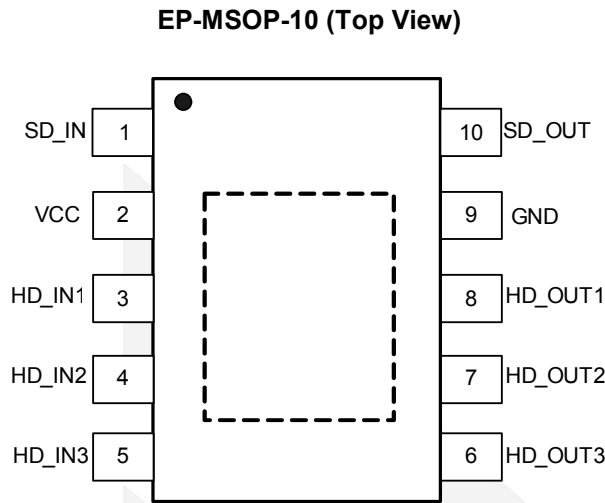

**Figure 1 Pin Assignment**

### Pin Description

Pin	Name	Type	Description
1	SD_IN	Input	Channel SD Video Input
2	VCC	Power	Positive Power Supply
3	HD_IN1	Input	Channel HD Video Input (Pr)
4	HD_IN2	Input	Channel HD Video Input (Pb)
5	HD_IN3	Input	Channel HD Video Input (Y)
6	HD_OUT3	Output	Channel HD Video Output (Y)
7	HD_OUT2	Output	Channel HD Video Output (Pb)
8	HD_OUT1	Output	Channel HD Video Output (Pr)
9	GND	Ground	Ground
10	SD_OUT	Output	Channel SD Video Output

## Absolute Maximum Ratings

Stresses beyond those listed under “Absolute Maximum Rating” may cause permanent damage to the device. These are stress ratings only and functional operation of the device at these or any other condition beyond those indicated in the operational sections of the specifications is not implied. Exposure to absolute maximum rating conditions for extended periods may affect device reliability.

Parameter		Rating	Unit
Supply Voltage		-0.3 to 6.0	V
Input Voltage		-0.3 to $V_{CC}+0.3$	V
Storage Temperature Range		-65 to 150	°C
Junction Temperature		150	°C
Lead Temperature Range		260	°C
MSOP-10 $\theta_{JA}$		190	°C/W
ESD	HBM, JEDEC: JESD22-A114	8	kV

## Recommended Operating Conditions

The Recommended Operating Conditions table defines the conditions for actual device operation to ensure optimal performance to the datasheet specifications. DIOO does not recommend exceeding them or designing to Absolute Maximum Ratings.

Parameter		Rating	Unit
Supply Voltage		3.135 to 5.25	V
Operating Temperature Range		-40 to 85	°C



### Electrical Characteristics

Typical value:  $T_A = 25^\circ\text{C}$ ,  $V_{CC}=5\text{V}$ ,  $R_{SOURCE}=37.5\Omega$ ,  $R_L=150\Omega$  loads; referenced to 400kHz, all inputs are AC couple with  $0.1\mu\text{F}$ ; all outputs are AC coupled with  $220\mu\text{F}$ ; unless otherwise specified.

Symbol	Parameter	Conditions	Min.	Typ.	Max.	Unit
<b>DC ELECTRICAL CHARACTERISTICS</b>						
$I_{CC}$	Supply Current			73	80	mA
$V_{IN}$	Video Input Voltage Range		GND		1.4	$V_{PP}$
$V_{OS}$	Output Offset Voltage	$V_{IN}=0\text{V}$ , no load		350		mV
PSRR	Power Supply Rejection			-50	-60	dB
<b>HIGH DEFINITION AC PERFORMANCE</b>						
AV	Channel Gain		5.8	6.0	6.2	dB
BW	Band Width	$\pm 0.5\text{dB}$ , $R_{SOURCE}=75\Omega$		26		MHz
		-1dB, $R_{SOURCE}=75\Omega$		31		
		-3dB, $R_{SOURCE}=75\Omega$		37		
AR	Attenuation	$f=37.125\text{MHz}$ , $R_{SOURCE}=75\Omega$		-4.6		dB
		$f=44.25\text{MHz}$ , $R_{SOURCE}=75\Omega$		-10.5		
		$f=74.25\text{MHz}$ , $R_{SOURCE}=75\Omega$		-33		
THD	Output Distortion	$V_{OUT}=1.4V_{PP}$ , $f=10\text{MHz}$		0.6		%
		$V_{OUT}=1.4V_{PP}$ , $f=15\text{MHz}$		0.8		
$X_{TALK}$	Crosstalk	$f=1\text{MHz}$ , $V_{IN}=1.4V_{PP}$		-75		dB
SNR	Signal to Noise Ratio	100kHz to 30MHz, 100% White Signal		65		dB
	Group Delay	100kHz to 30MHz		5		ns
	Propagation Delay	Input to Output		20		ns
SR	Slew Rate	2V Output 90% to 10%		90		V/ $\mu\text{s}$
<b>STANDARD DEFINITION AC PERFORMANCE</b>						
AV	Channel Gain		5.8	6.0	6.2	dB
BW	Bandwidth	-1dB		8.0		MHz
		-3dB		9.0		
AR	Attenuation	$F=27\text{MHz}$		-56		dB
DG	Differential Gain			0.6		%
DP	Differential Phase			1.2		$^\circ$
THD	Output Distortion	$F=4\text{MHz}$		1.5		%
$X_{TALK}$	Crosstalk	$f=1\text{MHz}$		-85		dB
SNR	Signal to Noise Ratio			70		dB
$t_{PD}$	Propagation Delay			80		ns
	Group Delay	$f=400\text{kHz}$ , 6.5MHz		10		ns
CLG_SD	Chroma Luma Gain	$f=3.58\text{MHz}$ ref to SD in at 400kHz		100		%
CLD_SD	Chroma Luma Delay	$f=3.58\text{MHz}$ ref to SD in at 400kHz		5.5		ns

Notes:  $\text{SNR}=20 \cdot \log(714\text{mV} / \text{rms noise})$ .

Specifications subject to change without notice.

## Typical Performance Characteristics

Typical value:  $T_A = 25^\circ\text{C}$ ,  $V_{CC}=5\text{V}$ ,  $R_{SOURCE}=37.5\Omega$ ,  $R_L=150\Omega$  loads; referenced to 400kHz, all inputs are AC couple with  $0.1\mu\text{F}$ ; all outputs are AC coupled with  $220\mu\text{F}$ ; unless otherwise specified.

### $I_{CC}$ vs. $V_{CC}$

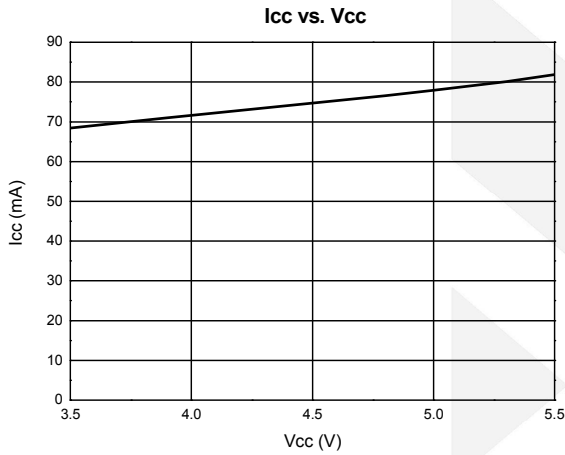

### $I_{CC}$ vs. Temperature

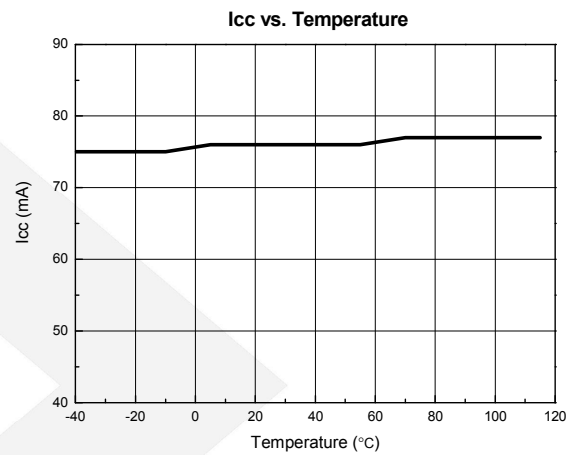

### CVBS BW vs. Frequency

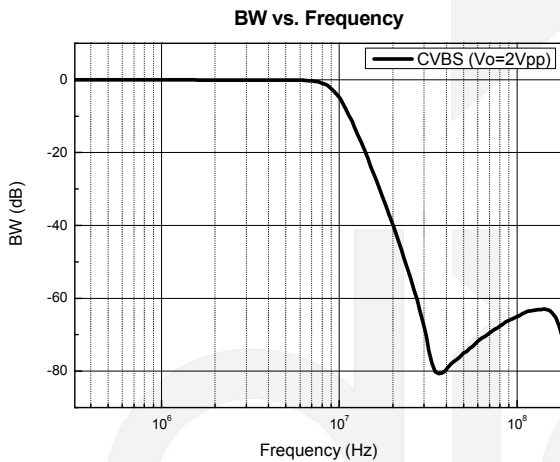

### HD BW vs. Frequency

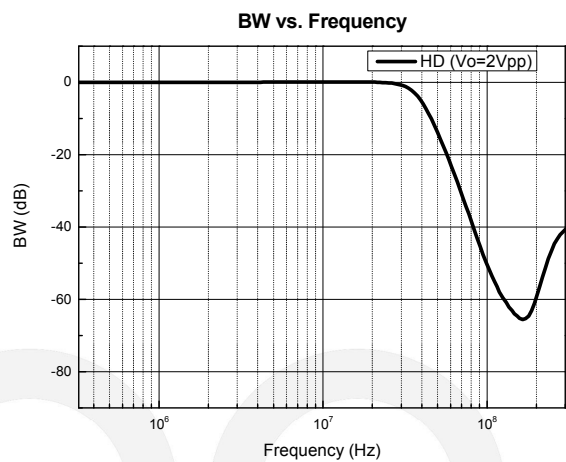

## Application Circuit

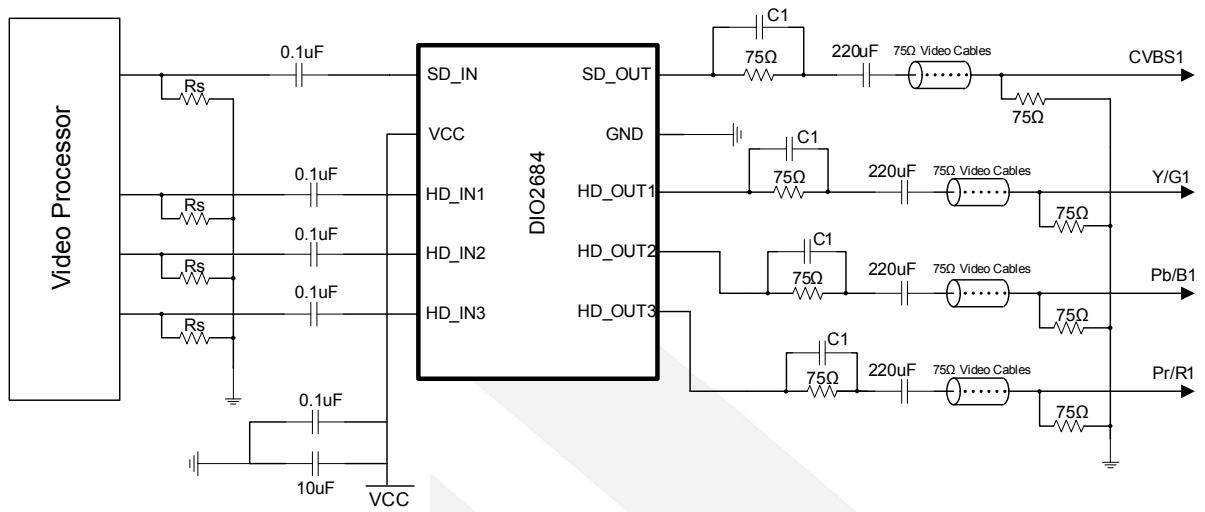

**Figure 2** Input and Output AC-Coupling Application

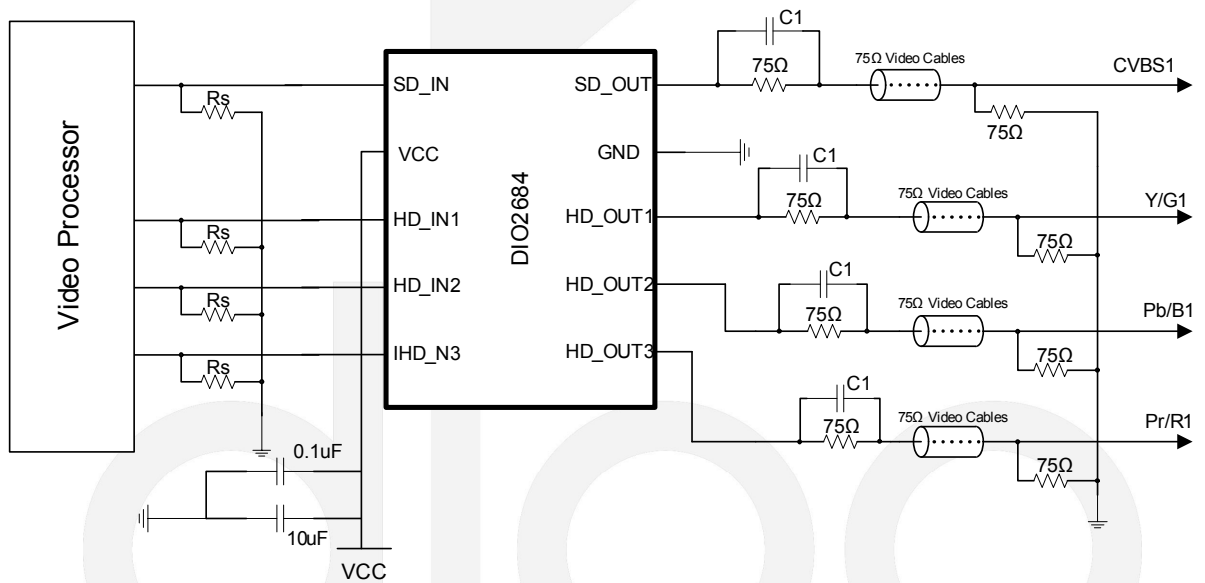

**Figure 3** Input and Output DC-Coupling Application

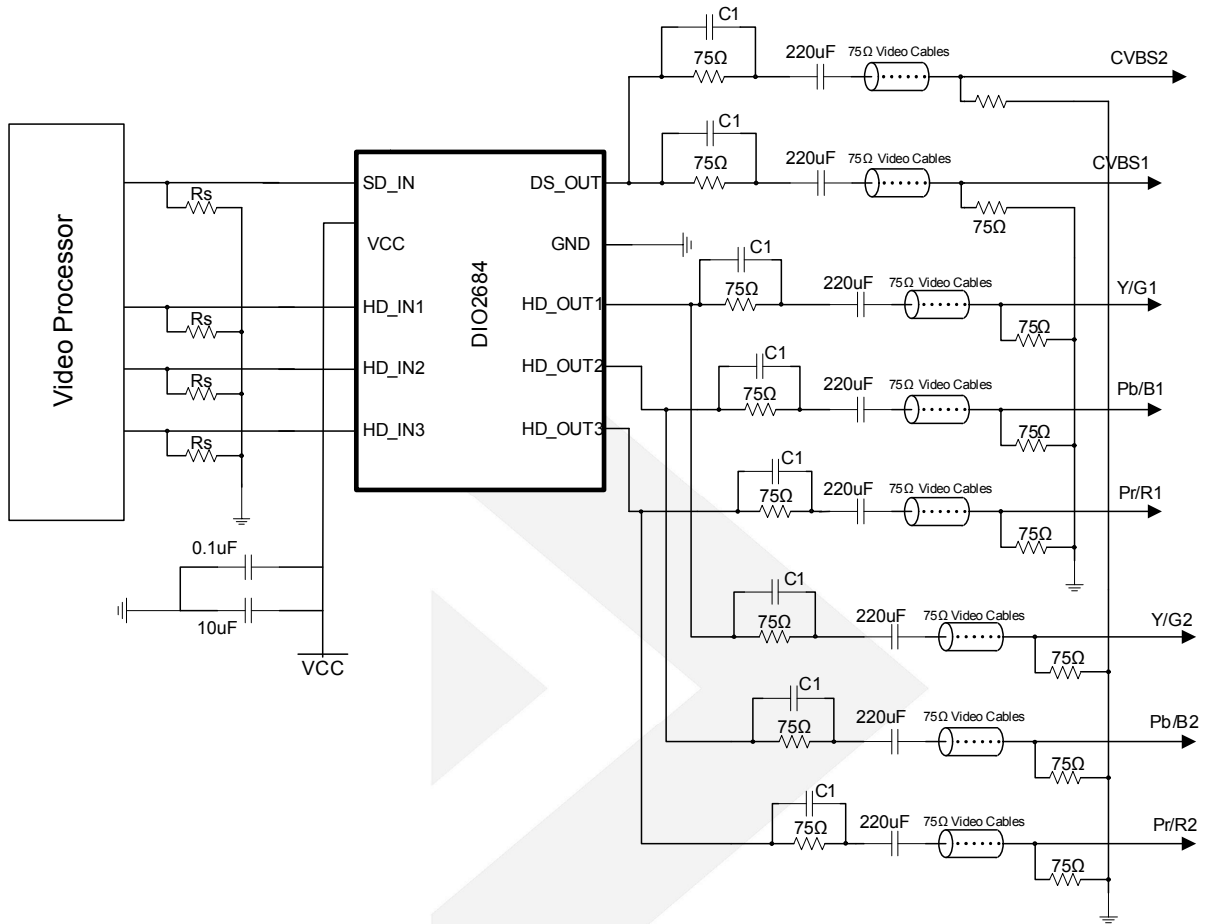

**Figure 4 Input DC-Coupling Application and Output AC-Coupling with Double Load**

**Note:** The value of C1 is recommended 2 to 4pF



## CONTACT US

Dioo is a professional design and sales corporation for high-quality and performance analog semiconductors. The company focuses on industry markets, such as, cell phone, handheld products, laptop, and medical equipment and so on. Dioo's product families include analog signal processing and amplifying, LED drivers and charger IC. Go to <http://www.dioo.com> for a complete list of Dioo product families.

For additional product information, or full datasheet, please contact with our Sales Department or Representatives.

