

DIO32220

Low-Power, USB2.0 High-Speed Switch

Features

- Super high bandwidth (-3dB): > 2.0GHz
- V_{CC} operation at 2.7V to 5.5V
- Low Con: 3pF Typical
- Low Ron: 6Ω Typical
- Low Power Consumption: 1μA Maximum
- Low I_{CCT} : 8μA Max @ $V_{IN}=1.8V$, $V_{CC}=3.6V$
- Packaged in Green MSOP-10, DQFN-10 and QFN-10
- 6kV HBM ESD on all pins
- Power-Off/On Protection on Common ports
D+/D- Pins Tolerate up to 5.5V

Descriptions

The DIO32220 is a low power, dual SPDT2-port high-speed analog switch. It handles bi-directional signal flow optimized for switching a hi-speed (480Mbps) source or a full-speed (12Mbps) source.

DIO32220 has high channel-to-channel noise isolation and low bit-to-bit skew which allows it to pass high-speed differential signals with good signal integrity. Each switch offers little or no attenuation of the high-speed signals at the outputs.

The DIO32220 contains special circuitry on the D+/D- pins, which can tolerate up to 5.5V when the USB devices either powered off or powered on.

DIO32220 is available in three type Green packages: DQFN-10, QFN-10, and MSOP-10 package.

Applications

- Cell-Phone/PDA
- MP3/MP4/PMP
- STB/LCDTV

Block Diagram

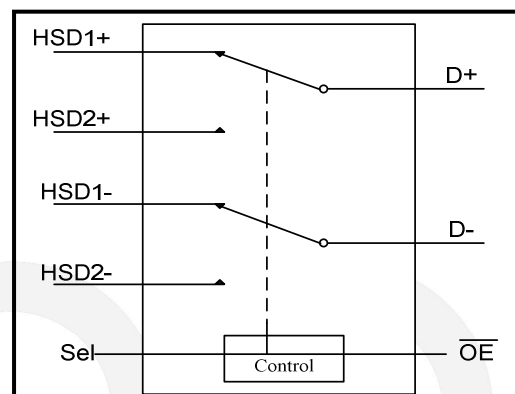

Ordering Information

Order Part Number	Top Marking		T_A	Package	
DIO32220MP10	DIO3222	Green	-40 to 85°C	MSOP-10	Tape & Reel, 3000
DIO32220LP10	YW2A	Green	-40 to 85°C	DQFN-10	Tape & Reel, 3000
DIO32220QN10	YW2A	Green	-40 to 85°C	QFN-10	Tape & Reel, 3000

Marking Definition

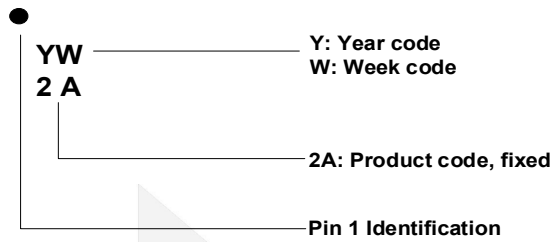

Pin Assignment

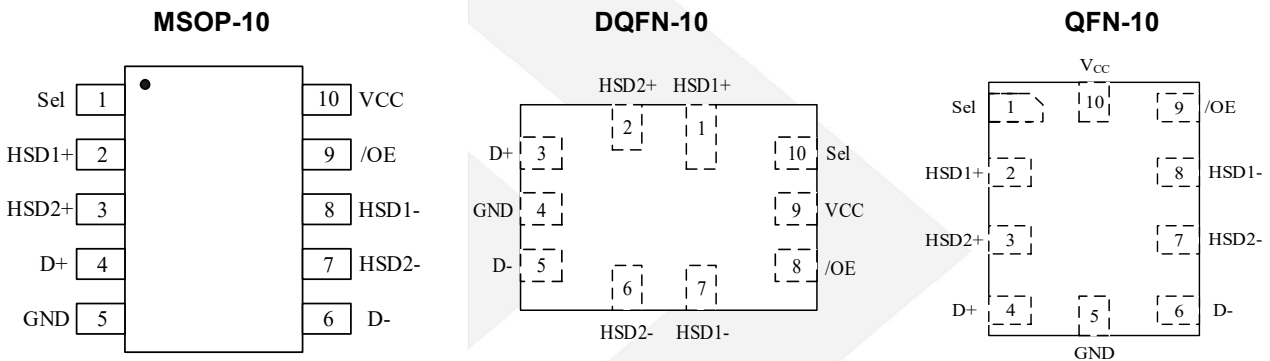

Figure 1. Top View

Pin Descriptions

Pin Name	Description
/OE	Switch Enable
Sel	Switch Select
D+, D-	USB Data Bus
HSDn+, HSDn-	Multiplexed Source inputs

Truth Table

Sel	/OE	Function
X	H	Disconnect
L	L	D+, D- = HSD1+, HSD1-
H	L	D+, D- = HSD2+, HSD2-



DIO32220

Low-Power, USB2.0 High-Speed Switch

Absolute Maximum Ratings

Stresses beyond those listed under "Absolute Maximum Rating" may cause permanent damage to the device. These are stress ratings only and functional operation of the device at these or any other condition beyond those indicated in the operational sections of the specifications is not implied. Exposure to absolute maximum rating conditions for extended periods may affect device reliability.

Symbol	Parameter	Min.	Max.	Unit
V_{CC}	Supply Voltage	-0.3	6.0	V
V_{CNTRL}	DC input Voltage(S, /OE)	-0.3	V_{CC}	V
V_{SW}	DC input I/O Voltage	-0.3	$V_{CC} + 0.3$	V
	DC input I/O Voltage (D+/D-)	-0.3	6.0	V
I_{IK}	DC input Diode current	-50		mA
I_{OUT}	DC output current		50	mA
T_{STG}	Storage Temperature	-65	150	°C
ESD	HBM, JEDEC: JESD22-A114 All Pins	6		kV

Recommend Operating Conditions

The Recommended Operating Conditions table defines the conditions for actual device operation. Recommended Operating conditions are specified to ensure optimal performance to the datasheet specifications. DIOO does not Recommend exceeding them or designing to Absolute Maximum Ratings.

Symbol	Parameter	Min.	Max.	Unit
V_{CC}	Supply voltage	2.7	5.5	V
V_{CNTRL}	Control input voltage(S,/OE)	0	V_{CC}	V
V_{SW}	Switch I/O voltage (HSD1±, HSD2±)	0	V_{CC}	V
	Switch I/O voltage (D+, D-)	0	5.5	V
T_A	Operating Temperature	-40	85	°C



DIO32220

Low-Power, USB2.0 High-Speed Switch

DC Electrical Characteristics

All typical value are at $T_A = 25^\circ\text{C}$ unless otherwise specified.

Symbol	Parameter	Conditions	V _{CC} (V)	Min.	Typ.	Max.	Unit
V _{IH}	Input voltage high		3.0 to 3.6	1.2			V
V _{IL}	Input voltage low		3.0 to 3.6			0.6	V
I _{IN}	Control input leakage	V _{SW} = 0 to V _{CC}	3.6	-1		1	uA
I _{OZ}	Off state leakage	0 <= Dn, HSD1n, HSD2n <= 3.6V	3.6	-2		2	uA
I _{OFF}	Power-Off leakage current (All common ports)	V _{SW} = 0V to 3.6V, V _{CC} = 0V, See Figure 4	0	-2		2	uA
R _{ON}	HS switch on Resistance	V _{SW} =0.4V, I _{ON} =8mA, See Figure 3	3.0		6	8	Ω
ΔR _{ON}	HS Delta R _{ON}	V _{SW} =0.4V, I _{ON} =8mA	3.0		0.08		Ω
I _{CC}	Quiescent supply current	V _{CTRL} =0 or V _{CC} ,	3.6			1	uA
I _{CCT}	Increase in I _{CC} current per control voltage and V _{CC}	V _{CTRL} =2.6V, V _{CC} =3.6V	3.6			2	uA
		V _{CTRL} =1.8V, V _{CC} =3.6V	3.6			8	uA





DIO32220

Low-Power, USB2.0 High-Speed Switch

AC Electrical Characteristics

All typical value are for Vcc = 3.3V at 25°C unless otherwise specified.

Symbol	Parameter	Conditions	Vcc(V)	Temp	Min.	Typ.	Max.	Unit
				(°C)				
t _{ON}	Turn-On time S, /OE to output	R _L =50Ω, C _L =5pF, V _{SW} = 0.8V,See Figure 10	3.0 to 3.6	full		10	20	ns
t _{OFF}	Turn-Off time S, /OE to output	R _L =50Ω, C _L =5pF, V _{SW} = 0.8V,See Figure 10	3.0 to 3.6	full		5	10	ns
t _{PD}	Propagation delay	R _L =50Ω, C _L =5pF	3.3	25°C		0.25		ns
				full			5.0	ns
t _{BMM}	Break-Before-Make	R _L =50Ω, C _L =5pF, V _{SW} =0.8V,See Figure 9	3.0 to 3.6	25°C		12		ns
				full	10		28	ns
OIRR	Off Isolation	R _L =50Ω, f=240MHz See Figure 8	3.0 to 3.6	25°C		-37		dB
Xtalk	Non-Adjacent Channel Crosstalk	R _L =50Ω, f=240MHz See Figure 7	3.0 to 3.6	25°C		-45		dB
BW	-3dB bandwidth	R _L =50Ω, C _L =0pF, See Figure 6	3.0 to 3.6	25°C		2000		MHz
		R _L =50Ω, C _L =5pF, See Figure 6		25°C		720		MHz
t _{SK(P)}	Skew of Opposite Transitions of the same output	R _L =50Ω, C _L =5pF	3.0 to 3.6	25°C		20		ps

Capacitance

Symbol	Parameter	Conditions	Temp	Min.	Typ.	Max.	Unit
			(°C)				
C _{IN}	Control Pin input Capacitance	V _{CC} =0V	25°C		1.2		pF
C _{ON}	D+/D- on Capacitance	V _{CC} =3.3V, /OE=0V, f=240MHz, See Figure 5	25°C		3		
C _{OFF}	HSD1n, HSD2n off capacitance	V _{CC} and /OE=3.3V,See Figure 5	25°C		2		

Specifications subject to change without notice.

Typical Performance Characteristics

T_A= 25°C, V_{CC}= 3.3V, unless other otherwise specified.

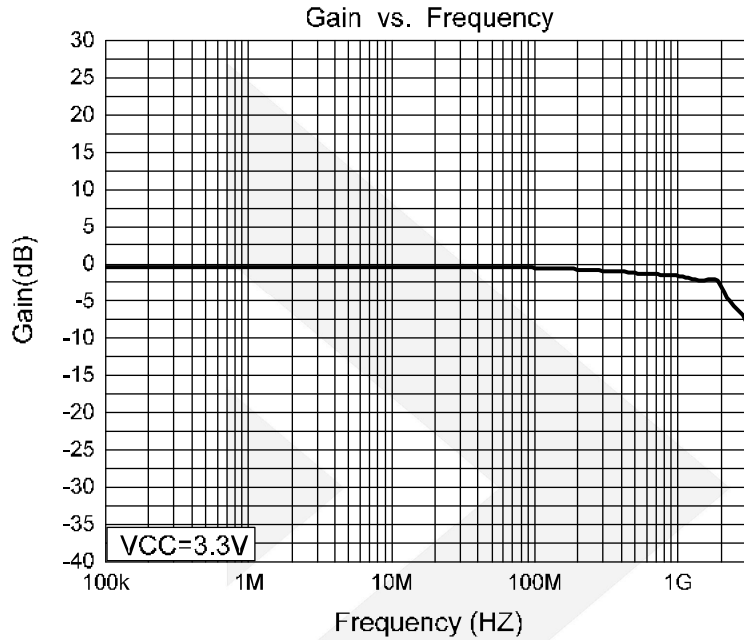

DIO32220 USB 2.0 high speed (480Mbps) eye pattern

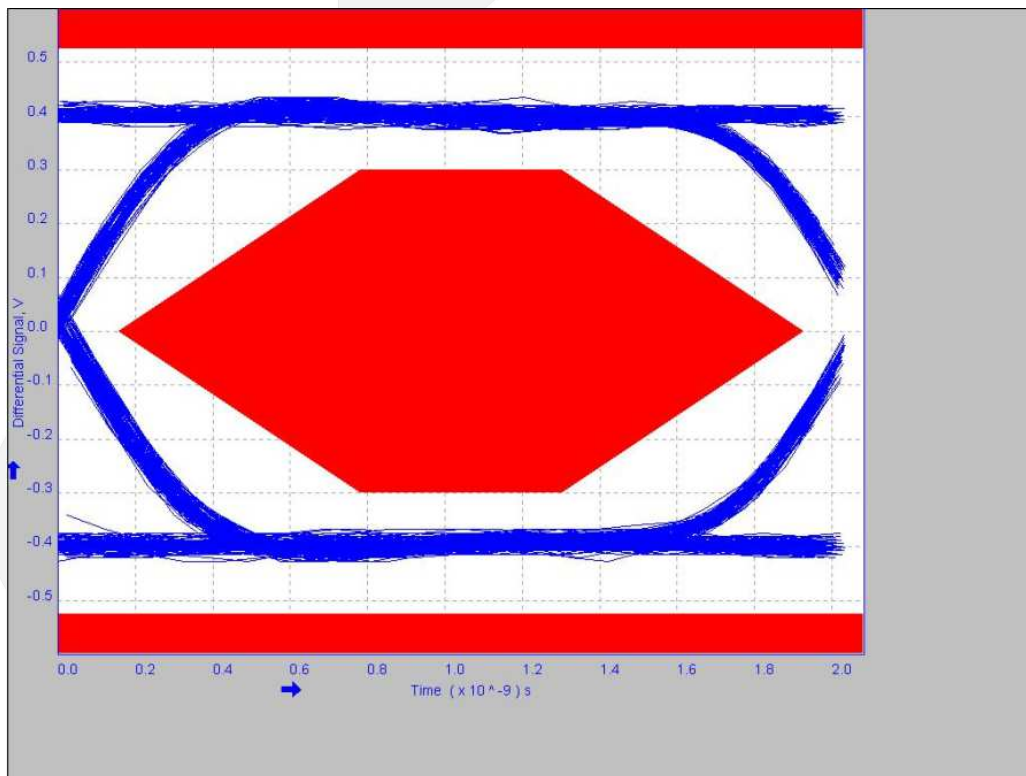
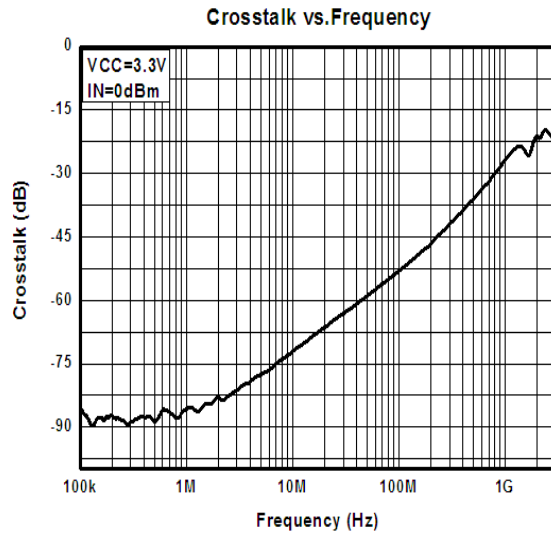
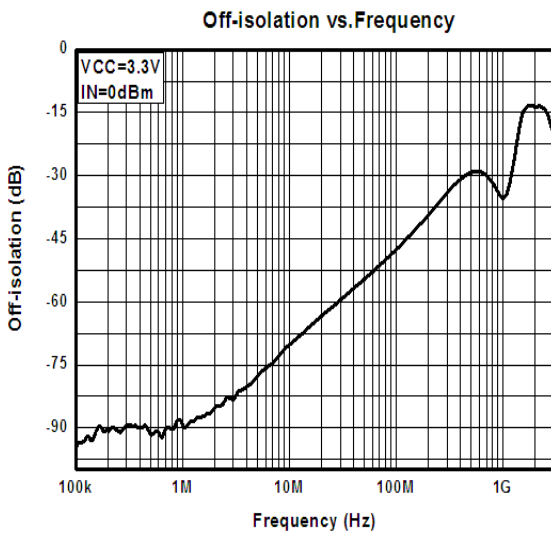
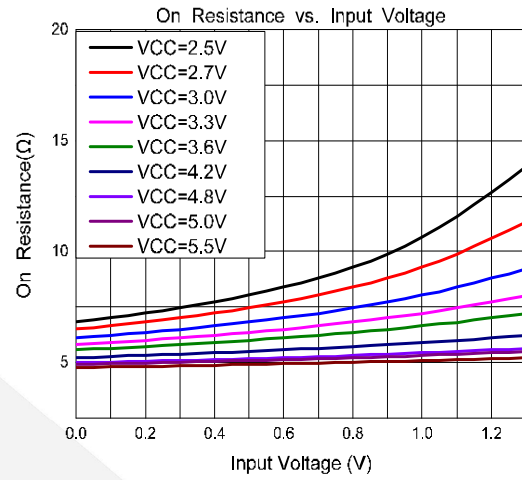
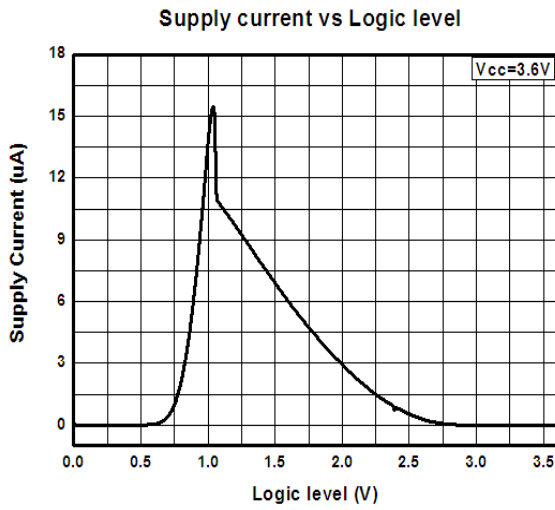

Figure 2. Eye Pattern: 480Mbps with USB switch In signal path



DIO32220

Low-Power, USB2.0 High-Speed Switch



Test Diagrams

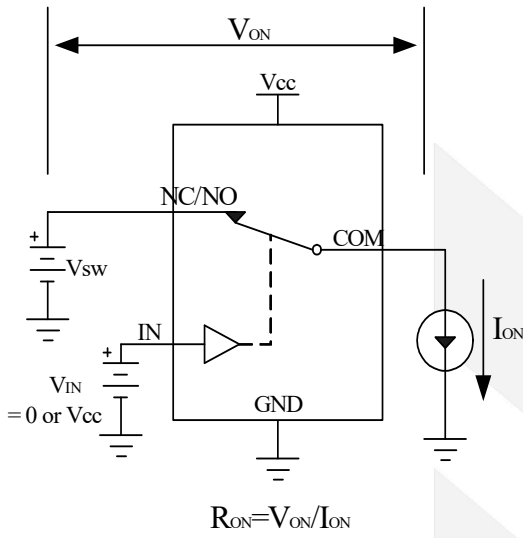

Figure 3. Switch on resistor

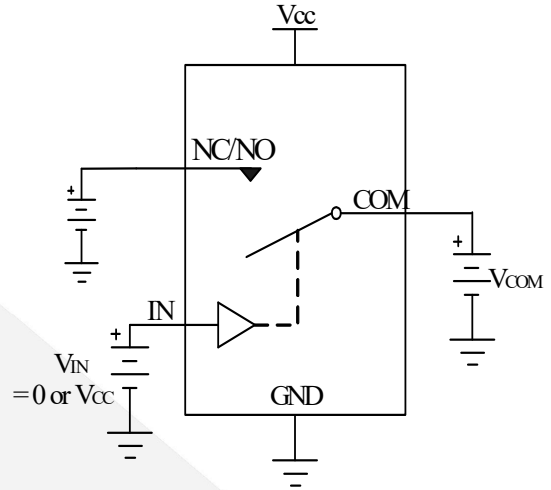

Figure 4. Switch Off Leakage

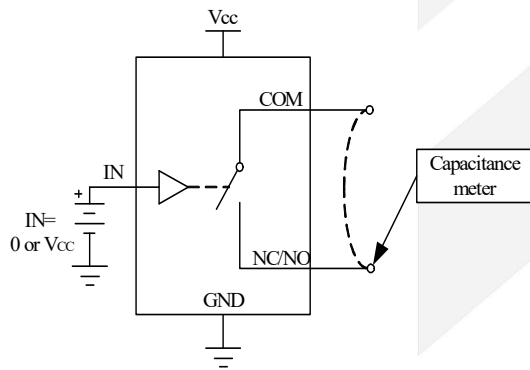

Figure 5. Channel ON/OFF Capacitance

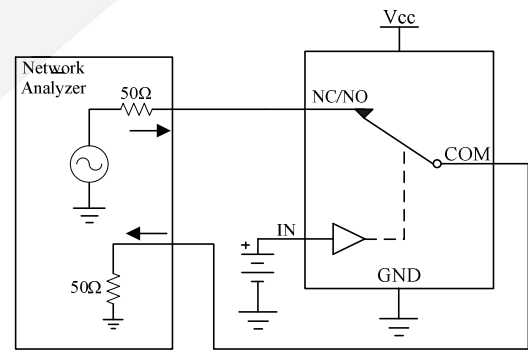

Figure 6. Bandwidth

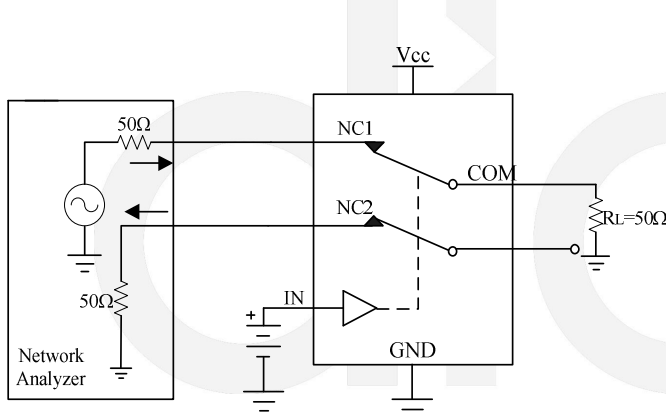

Figure 7. Channel-to-channel crosstalk

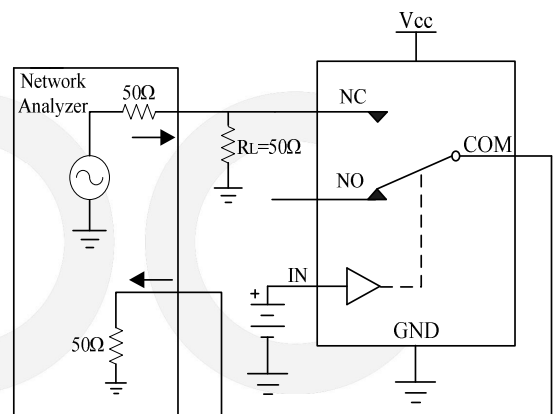

Figure 8. Off-isolation

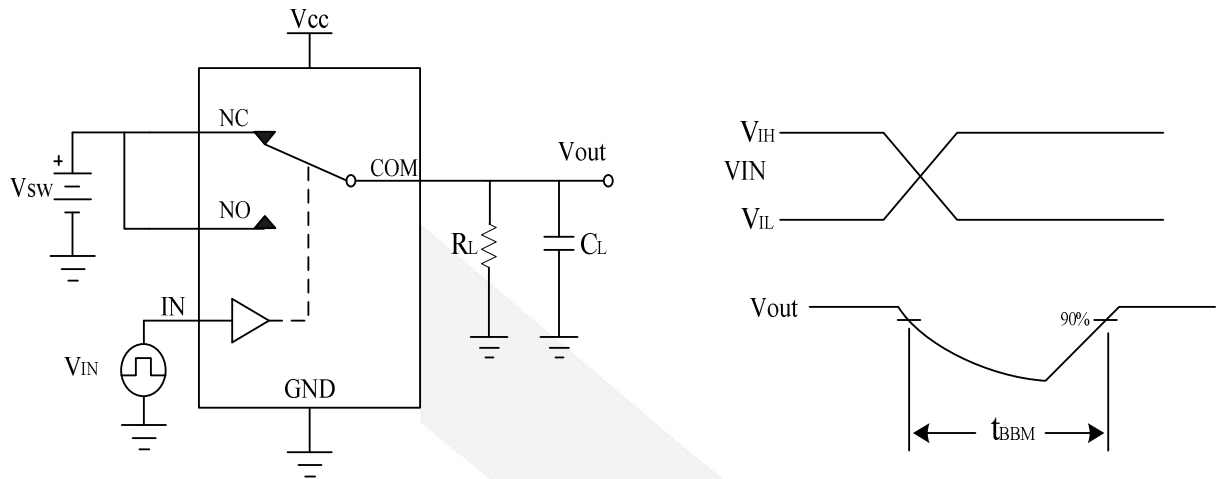

Figure 9. Break-Before-Make

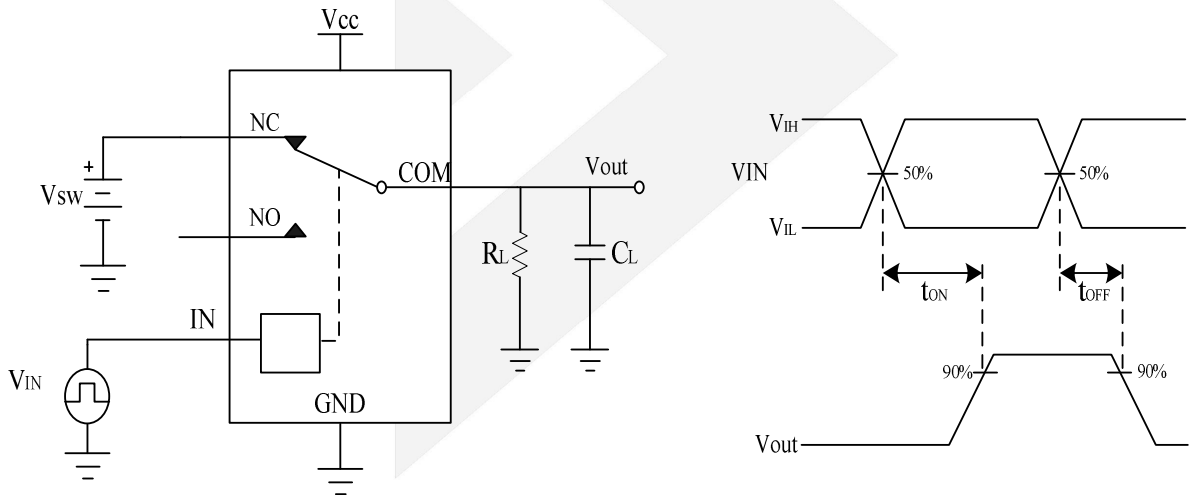

Figure 10. Turn-On/Turn-Off



CONTACT US

Dioo is a professional design and sales corporation for high-quality and performance analog semiconductors. The company focuses on industry markets, such as, cell phone, handheld products, laptop, and medical equipment and so on. Dioo's product families include analog signal processing and amplifying, LED drivers and charger IC. Go to <http://www.dioo.com> for a complete list of Dioo product families.

For additional product information, or full datasheet, please contact with our Sales Department or Representatives.

 dioo