

# DIO6328E

## High Efficiency 1MHz, 2.3A Step Up Regulator

### Features

- Wide input range:  
2.3-25V bias input, 25V Vout max
- 1MHz switching frequency
- Minimum on time: 100ns typical
- Minimum off time: 100ns typical
- Low  $R_{DS(ON)}$ : 0.15 $\Omega$
- RoHS Compliant and Halogen Free
- Accurate Reference: 0.6V<sub>REF</sub>
- Compact package: SOT23-6

### Descriptions

DIO6328E is a fixed frequency peak current mode asynchronous boost converter. Requires an external Schottky diode. DIO6328E works in light load mode when the load is light, and its quiescent current is about 100 $\mu$ A. The 150m $\Omega$   $R_{DS(ON)}$  of the integrated NMOS ensures the high efficiency in all load conditions. Input voltage range is 2.3V~25V. Internal operating frequency is set to 1.0MHz.

### Applications

- WLED Drivers
- Networking cards powered from PCI or PCI-express slots

Efficiency vs Load Current

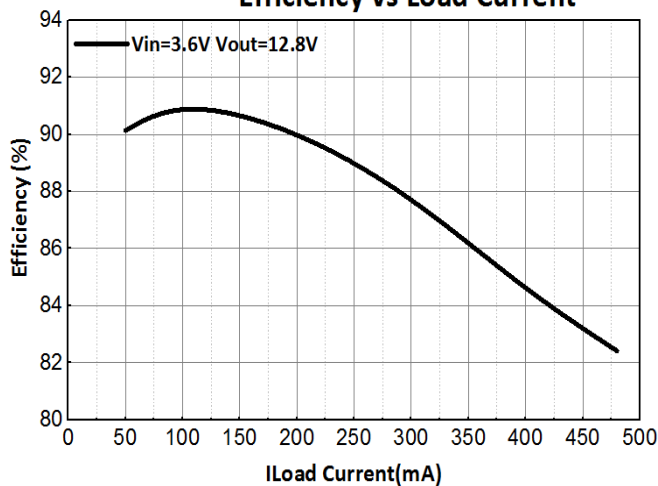

### Typical Application

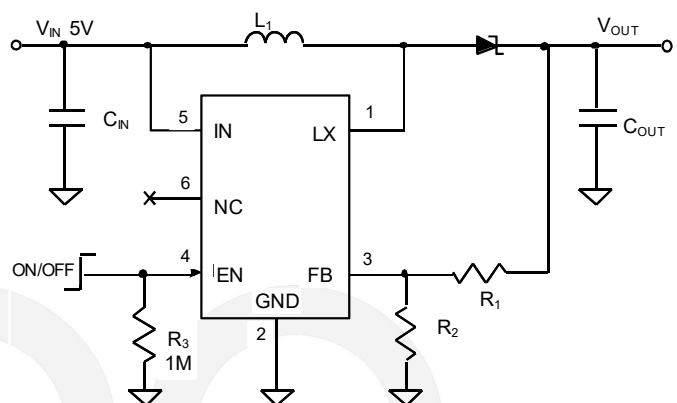

### Ordering Information

Order Part Number	Top Marking		T <sub>A</sub>	Package	
DIO6328EST6	YWEJ	Green	-40 to 85°C	SOT23-6	Tape & Reel, 3000

## Pin Assignment

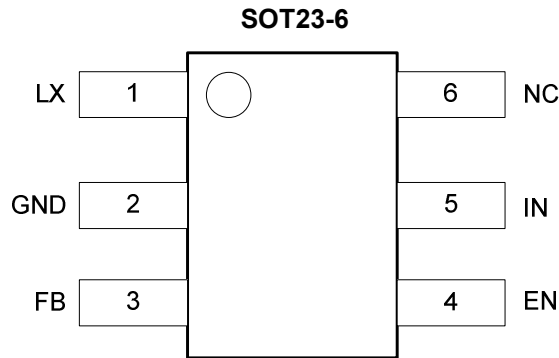

Figure 1 Top View

## Pin Descriptions

Name	Description
LX	Inductor node. Connect an inductor between IN pin and LX pin.
GND	Ground pin.
FB	Feedback pin. Connect a resistor R1 between VOUT and FB, and a resistor R2 between FB and GND to program the output voltage: $V_{OUT} = 0.6V * (R1 / R2 + 1)$ .
EN	Enable control. High to turn on the part. Don't leave it floated.
IN	Input pin. Decouple this pin to GND pin with 1µF ceramic cap.
NC	No connected.



# DIO6328E

High Efficiency 1MHz, 2.3A Step Up Regulator

## Absolute Maximum Ratings

Stresses beyond those listed under “Absolute Maximum Rating” may cause permanent damage to the device. These are stress ratings only and functional operation of the device at these or any other condition beyond those indicated in the operational sections of the specifications is not implied. Exposure to absolute maximum rating conditions for extended periods may affect device reliability.

Parameter		Rating	Unit
IN, EN		28	V
LX		28	V
All other pins		6	V
Power Dissipation, P <sub>D</sub>		0.4	W
Package Thermal Resistance	$\theta_{JA}$	250	°C/W
	$\theta_{JC}$	130	°C/W
Junction Temperature Range		150	°C
Lead Temperature		260	°C
Storage Temperature Range		-65 to 150	°C
ESD	HBM	2	kV

## Recommend Operating Conditions

The Recommended Operating Conditions table defines the conditions for actual device operation. Recommended Operating conditions are specified to ensure optimal performance to the datasheet specifications. DIOO does not Recommend exceeding them or designing to Absolute Maximum Ratings.

Parameter		Rating	Unit
IN,LX		2.3 to 25	V
All other pins		0 to 5.5	V
Junction Temperature Range		-40 to 125	°C
Ambient Temperature Range		-40 to 85	°C



# DIO6328E

High Efficiency 1MHz, 2.3A Step Up Regulator

## Electrical Characteristics

Typical value:  $V_{IN}=5V$ ,  $V_{OUT}=12V$ ,  $I_{OUT}=100mA$ ,  $T_A=25^{\circ}C$ , unless otherwise specified.

Symbol	Parameter	Conditions	Min.	Typ.	Max.	Unit
$I_Q$	Quiescent Current	FB=0.66V		100		$\mu A$
$I_{SHDN}$	Shutdown Current	EN=0		1	5	$\mu A$
$R_{DS(ON)}$	Low Side Main FET RON			150		m $\Omega$
$I_{LIM}$	Main FET Current Limit		2.3		2.9	A
$F_{SW}$	Switching Frequency		0.8	1	1.2	MHz
$V_{REF}$	Feedback Reference Voltage		0.588	0.6	0.612	V
OVP	OUT OVP		26			V
$T_{SD}$	Thermal Shutdown Temperature			150		$^{\circ}C$
$V_{ENH}$	EN Rising Threshold		1.4			V
$V_{ENL}$	EN Falling Threshold				0.4	V
$I_{EN}$	EN Pin Input Current		0		100	nA

Specifications subject to change without notice.

## Typical Performance Characteristics

All typical value are at  $V_{in}=3.6V$ ,  $V_{out}=12V$ ,  $L=10\mu H$ ,  $C_{out}=2*10\mu F$ ,  $T_A=25^\circ C$ , unless otherwise specified.

**Figure 2. Line Regulation @ 200mA**

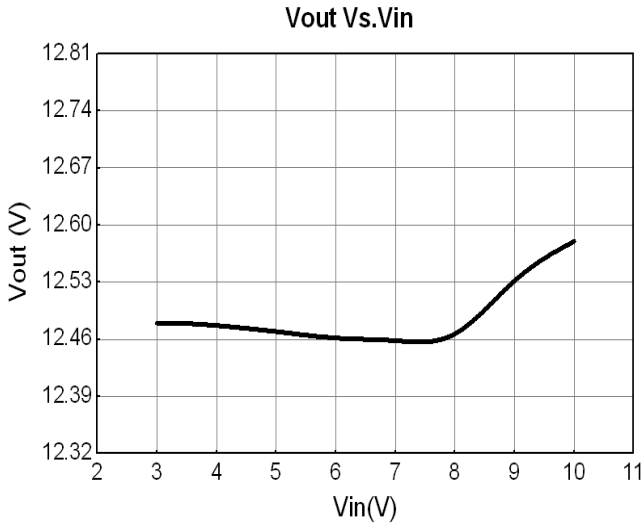

**Figure 3. Load Regulation**

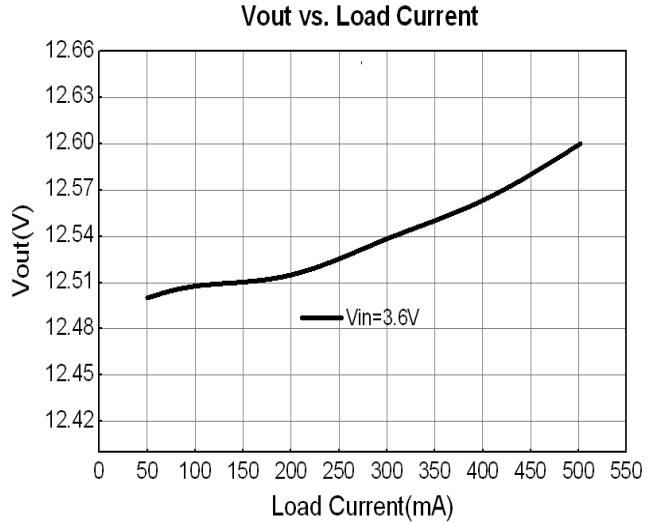

**Figure 4. Output voltage VS Input voltage**

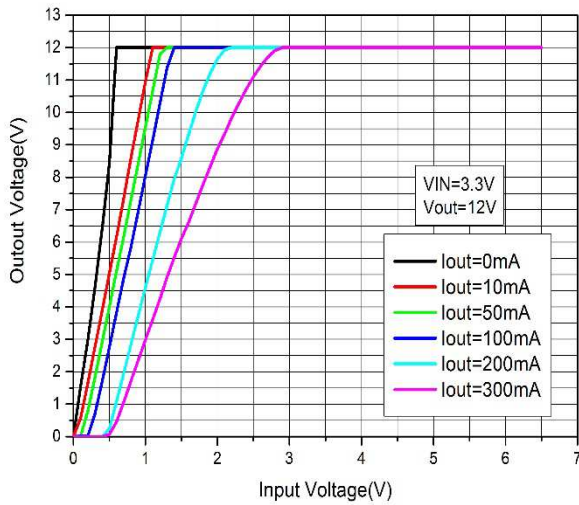

**Figure 5. Phase Margin (Vin=5V Load=100mA)**



Figure 6. Power On @ No Load

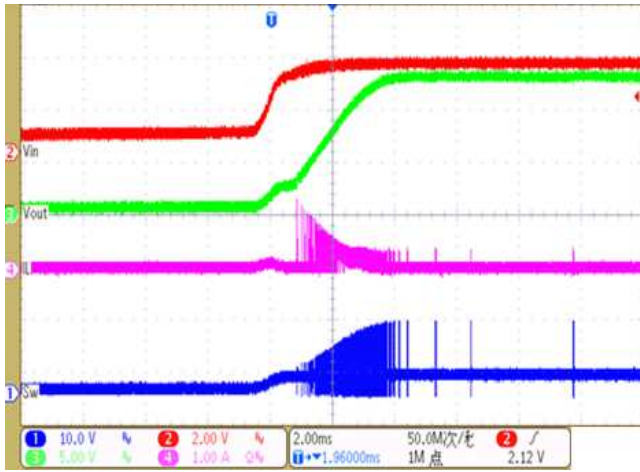

Figure 7. Power Off @ No Load

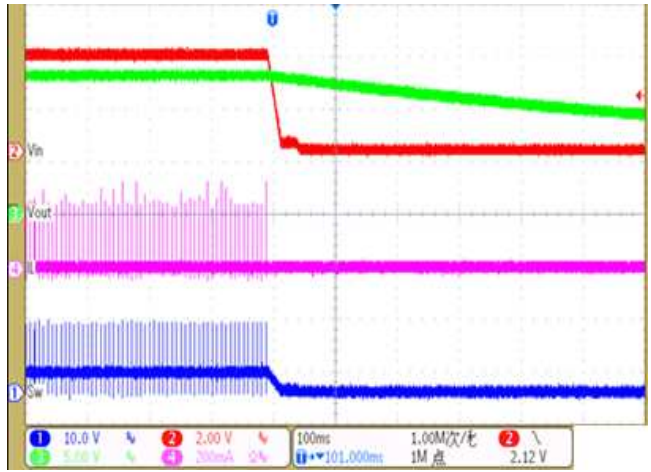

Figure 8. Enable Start Up @ Load=0.45A

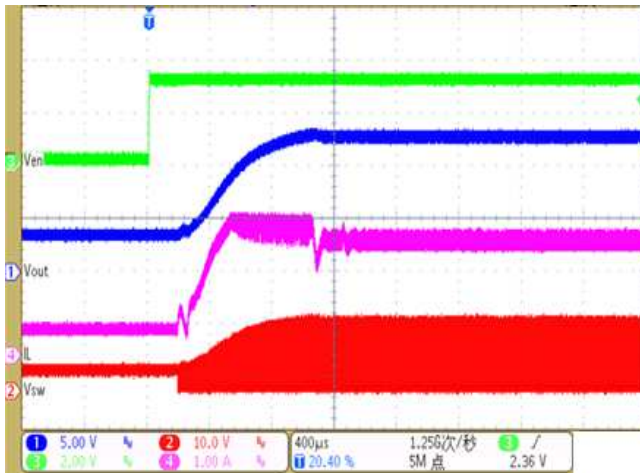

Figure 9. Enable Shut Down @ Load=0.45A

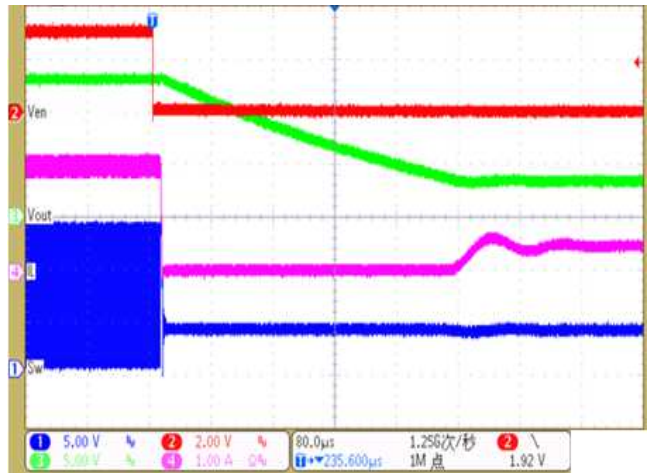

Figure 10. Ripple Burst mode @ Load=0.03A

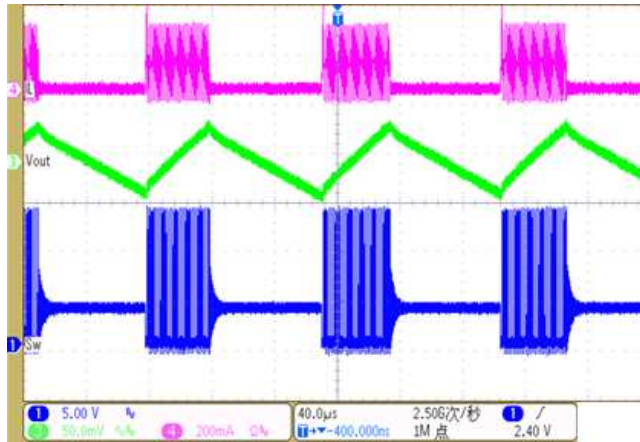

Figure 11. Ripple CCM mode @ Load=0.2A

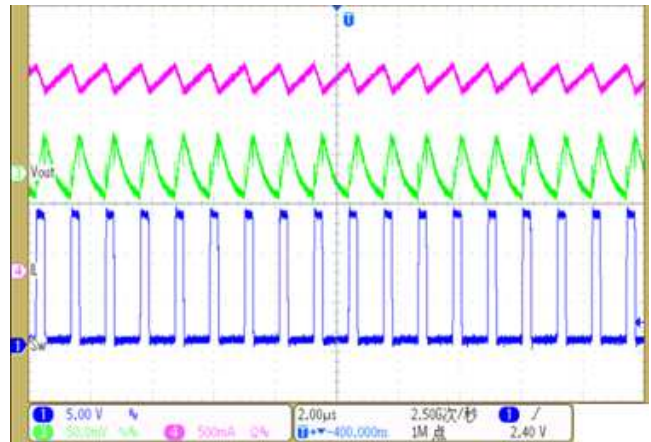
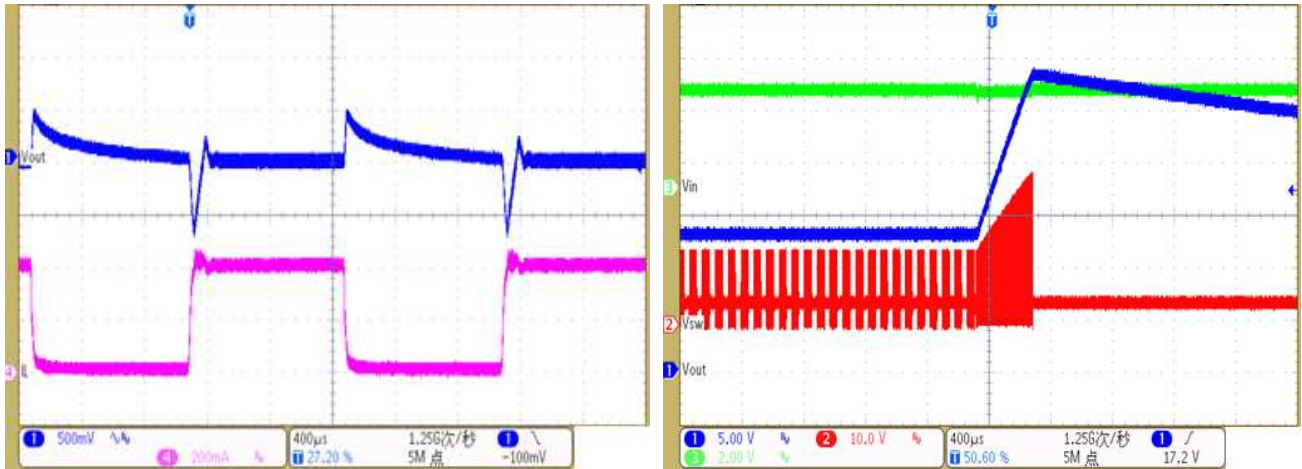

Figure 12. Load Transient (Load=0->400mA)    Figure 13. Output Over Voltage Protection Load=0.01A



## Application Information

Because of the high integration in the DIO6328E IC, the application circuit based on this regulator IC is rather simple. Only input capacitor  $C_{IN}$ , output capacitor  $C_{OUT}$ , inductor  $L$  and feedback resistor ( $R_1$  and  $R_2$ ) need to be selected for the targeted applications specifications.

### Feedback resistor dividers $R_1$ and $R_2$ :

Choose  $R_1$  and  $R_2$  to program the proper output voltage. To minimize the power consumption under light loads, it is desirable to choose large resistance values for both  $R_1$  and  $R_2$ . A value of between 10k and 1M is recommended for both resistors. If  $R_2=10k$  is chosen, then  $R_1$  can be calculated to be:

$$R_1 = \frac{(V_{OUT} - 0.6V) \times R_2}{0.6V}$$

### Input capacitor $C_{IN}$ :

The ripple current through input capacitor is calculated as:

$$I_{CIN\_RMS} = \frac{V_{IN} \cdot (V_{OUT} - V_{IN})}{2\sqrt{3} \cdot L \cdot F_{SW} \cdot V_{OUT}}$$

To minimize the potential noise problem, place a typical X7R or better grade ceramic capacitor really close to the IN and GND pins. Care should be taken to minimize the loop area formed by  $C_{IN}$ , and IN/GND pins.

### Output capacitor $C_{OUT}$ :

The output capacitor is selected to handle the output ripple noise requirements. Both steady state ripple and transient requirements must be taken into consideration when selecting this capacitor. For the best performance, it is recommended to use X7R or better grade ceramic capacitor with 25V rating and greater than 10 $\mu$ F capacitance.

### Output inductor $L$ :

There are several considerations in choosing this inductor.

1. Choose the inductance to provide the desired ripple current. It is suggested to choose the ripple current to be about 40% of average input current. The inductance is calculated as:

$$L = \left( \frac{V_{IN}}{V_{OUT}} \right)^2 \frac{(V_{OUT} - V_{IN})}{F_{SW} \times I_{OUT, MAX} \times 40\%}$$

Where  $F_{SW}$  is the switching frequency and  $I_{OUT, MAX}$  is the maximum load current.

The DIO6328E regulator IC is quite tolerant of different ripple current amplitude. Consequently, the final choice of inductance can be slightly off the calculation value without significantly impacting the performance.

2. The saturation current rating of the inductor must be selected to be greater than the peak inductor current under full load conditions.

$$I_{SAT, MIN} > \left( \frac{V_{OUT}}{V_{IN}} \right) \times I_{OUT, MAX} + \left( \frac{V_{IN}}{V_{OUT}} \right)^2 \frac{(V_{OUT} - V_{IN})}{2 \times F_{SW} \times L}$$

3. The DCR of the inductor and the core loss at the switching frequency must be low enough to achieve the desired efficiency requirement. It is desirable to choose an inductor with  $DCR < 50\text{mohm}$  to achieve a good overall efficiency.

### Applications with Large Bulk Capacitance

In applications with large bulk capacitance on the output, a very high inrush current can be seen flow into the IC and cause any unexpected damage, a Zener diode connected from power input to the output or an RC delay circuit added on EN pin of the IC can be used. Refer to the circuit below.

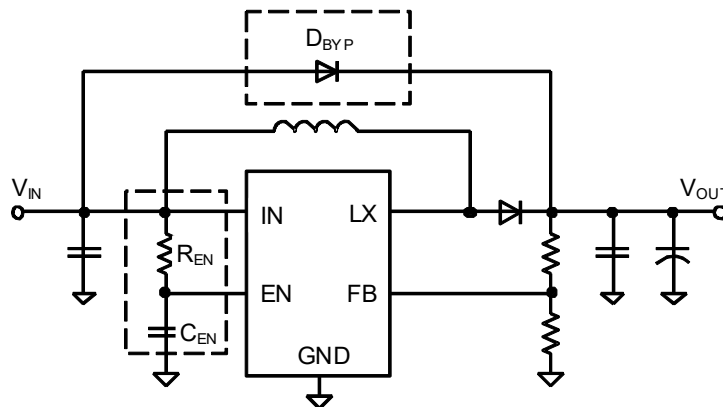

### Layout Design:

The layout design of DIO6328E regulator is relatively simple. For the best efficiency and minimum noise problems, we should place the following components close to the IC:  $C_{IN}$ , L,  $R_1$  and  $R_2$ .

- 1) It is desirable to maximize the PCB copper area connecting to GND pin to achieve the best thermal and noise performance. If the board space allowed, a ground plane is highly desirable.
- 2)  $C_{IN}$  must be close to pins IN and GND. The loop area formed by  $C_{IN}$  and GND must be minimized.





## DIO6328E

- 3) The PCB copper area associated with LX pin must be minimized to avoid the potential noise problem.
- 4) The components  $R_1$  and  $R_2$ , and the trace connecting to the FB pin must NOT be adjacent to the LX net on the PCB layout to avoid the noise problem.
- 5) If the system chip interfacing with the EN pin has a high impedance state at shutdown mode and the IN pin is connected directly to a power source such as a Li-Ion battery, it is desirable to add a pull down 1Mohm resistor between the EN and GND pins to prevent the noise from falsely turning on the regulator at shutdown mode.

High Efficiency 1MHz, 2.3A Step Up Regulator



## DIO6328E

High Efficiency 1MHz, 2.3A Step Up Regulator

### CONTACT US

Dioo is a professional design and sales corporation for high-quality and performance analog semiconductors. The company focuses on industry markets, such as, cell phone, handheld products, laptop, and medical equipment and so on. Dioo's product families include analog signal processing and amplifying, LED drivers and charger IC. Go to <http://www.dioo.com> for a complete list of Dioo product families.

For additional product information, or full datasheet, please contact with our Sales Department or Representatives.