

DIO5538B/C/D

5~100mA, Single Li-ion Battery Charger

Features

- Broad Programmable Charging Current:
5~100mA
- Over-Temperature Protection
- Under Voltage Lockout Protection
- Reverse current protection between BAT and GND pins
- Automatic Recharge Threshold:
DIO5538B: 4.05V (Typ.)
DIO5538C: 4.2V (Typ.)
DIO5538D: 4.25V (Typ.)
- Final Float Voltage:
DIO5538B: 4.2V
DIO5538C: 4.35V
DIO5538D: 4.4V
- Charge Status Output Pin
- 2.9V Trickle Charge Threshold
- Soft-Start Limits Inrush Current
- Over Voltage Lockout Protection
- <0.35mm thickness super thin DFN package

Descriptions

The DIO5538B/C/D is a complete constant-current / constant voltage linear charger for single cell Lithium-Ion batteries. No external sense resistor is needed, and no blocking diode is required due to the internal MOSFET architecture. Thermal feedback regulates the charge current to limit the die temperature during high power operation or high ambient temperature. The charge voltage is fixed at 4.2V for DIO5538B and 4.35V for DIO5538C and 4.4V for DIO5538D, and the charge current can be programmed externally with a single resistor.

The DIO5538B/C/D automatically terminates the charge cycle when the charge current drops to 1/10 the programmed value after the final float voltage is reached.

When the input supply (wall adapter or USB supply) is removed, the DIO5538B/C/D automatically enters a low current state, dropping the battery drain current to less than 0.5 μ A. The DIO5538B/C/D can be put into shutdown mode, reducing supply current to 40 μ A (Typ.).

The DIO5538B/C/D is available in a small package with DFN1.8*2-6. Standard product is Pb-Free.

Applications

- Wireless phone
- MP3/MP4 Player
- Bluetooth device

Ordering Information

Order Part Number	Top Marking		T _A	Package	
DIO5538BCN6	538B	Green	-40 to 85°C	DFN1.8*2-6	Tape & Reel, 3000
DIO5538CCN6	538C	Green	-40 to 85°C	DFN1.8*2-6	Tape & Reel, 3000
DIO5538DCN6	538D	Green	-40 to 85°C	DFN1.8*2-6	Tape & Reel, 3000

Pin Assignment

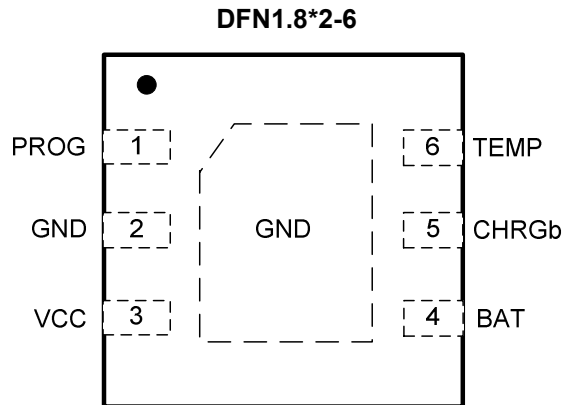

Figure 1. Top View

Pin Descriptions

Name	Description
PROG	Charge current setting, charge current monitor and shutdown pin. The charging current is given by $I_{BAT} = (1/R_{PROG}) * 100$. The chip will be shutdown when PROG pin floating.
GND	Ground.
VCC	Power Supply.
BAT	Charge Current Output. Provides charge current to the battery and regulates the final float voltage to 4.2V/4.35V/4.4V.
CHRGb	Open-Drain Charge Status Output. When the battery is charging, the CHRGb pin is pulled low. When the charge cycle is completed or VCC is removed, the CHRGb is forced high impedance.
TEMP	Battery Temperature Sense Pin. When the battery temperature is too high or too low, the charging current will be terminated.
GND(Expose Pad)	This pin must be connected to GND, and punch to the main GND to facilitate heat dissipation.



DIO5538B/C/D

5~100mA, Single Li-ion Battery Charger

Absolute Maximum Ratings

Stresses beyond those listed under “Absolute Maximum Rating” may cause permanent damage to the device. These are stress ratings only and functional operation of the device at these or any other condition beyond those indicated in the operational sections of the specifications is not implied. Exposure to absolute maximum rating conditions for extended periods may affect device reliability.

Parameter	Rating	Unit
Supply Voltage	-0.3~10	V
PROG Voltage	-0.3~VCC	V
BAT Voltage	-0.3~10	V
CHRGb Voltage	-0.3~VCC	V
BAT Pin Current	100	mA
Power Dissipation	0.6	W
Junction Temperature	150	°C
Storage Temperature	-65~125	°C
Lead Temperature (Soldering 10s)	260	°C

Recommend Operating Conditions

The Recommended Operating Conditions table defines the conditions for actual device operation. Recommended Operating conditions are specified to ensure optimal performance to the datasheet specifications. DIOO does not Recommend exceeding them or designing to Absolute Maximum Ratings.

Parameter	Rating	Unit
Input Supply Voltage	DIO5538B	4.5 to 5.5
	DIO5538C	4.65 to 5.5
	DIO5538D	4.65 to 5.5
Operating Temperature Range	-40 to 85	°C



DIO5538B/C/D

5~100mA, Single Li-ion Battery Charger

Electrical Characteristics

VCC=5V, TA=25°C (unless otherwise noted)

Symbol	Parameter	Conditions	Min.	Typ.	Max.	Unit
ISOLYCHRG	Charge Mode Supply Current	R _{PROG} =10kΩ		220	2000	μA
		R _{PROG} =20kΩ		220	2000	μA
IBATCHRG	Charge Mode Battery Current	R _{PROG} =5kΩ	18.4	20	21.6	mA
		R _{PROG} =10kΩ	9.2	10	10.8	mA
		R _{PROG} =20kΩ	4.6	5	5.4	mA
V _{PROGCHRG}	PROG Pin Voltage	R _{PROG} =10kΩ	0.93	1.00	1.07	V
		R _{PROG} =20kΩ	0.93	1.00	1.07	V
ISPLYSTBY	Standby Mode Supply Current	Charge Terminated		100	500	μA
IBATSTBY	Standby Mode Battery Current	Charge Terminated	0	-2.5	-6	pA
ISPLYASD	Shutdown Mode Supply Current	V _{CC} <V _{BAT}	20	40	90	μA
IBATASD	Shutdown Mode BAT Pin Current	V _{CC} <V _{BAT}		±0.05	±1	μA
ISPLYUVLO	UVLO Mode Supply Current	V _{CC} <V _{UV}	20	35	90	μA
IBATUVLO	UVLO Mode BAT Pin Current	V _{CC} <V _{UV}		±0.05	±1	nA
ISPLYOVLO	OVLO Mode Supply Current	V _{CC} >V _{OV}		40		μA
IBATOVLO	OVLO Mode BAT Pin Current	V _{CC} >V _{OV}		±0.05	±1	pA
ISPLYSHUT	Shutdown Mode Supply Current	R _{PROG} not Connected	20	40	70	μA
IBATSHUT	Shutdown Mode BAT Pin Current	R _{PROG} not Connected		±0.05	±1	pA
IBATMSD	Manual Shutdown BAT Pin Current	V _{PROG} =1.3V		±0.05	±1	pA
IBATSLEEP	Sleep Mode BAT Pin Current	V _{CC} =0V		±0.05	±1	nA
I _{Charge_terminated}	10mA/1mA charger terminated	R _{PROG} =10kΩ		10		μA
V _{Charge_terminated}		R _{PROG} =10kΩ		100		mV
V _{FLOAT}	Float Voltage	DIO5538B	4.158	4.2	4.242	V
		DIO5538C	4.31	4.35	4.39	
		DIO5538D	4.36	4.4	4.44	
I _{TRIKL}	Trickle Charge Current	R _{PROG} =10kΩ		1		mA
V _{TRIKL}	Trickle Charge Voltage Threshold	R _{PROG} =10kΩ	2.8	2.9	3.0	V
V _{TRIKL_HYS}	Trickle Charge Voltage Hysteresis	R _{PROG} =10kΩ		100		mV
V _{UVLO}	UVLO Threshold	From V _{CC} Low to High	3.6	3.8	4.0	V



DIO5538B/C/D

5~100mA, Single Li-ion Battery Charger

Electrical Characteristics (continued)

VCC=5V, T_A=25°C (unless otherwise noted)

Symbol	Parameter	Conditions	Min.	Typ.	Max.	Unit
V _{UVLO_HYS}	UVLO Hysteresis			250		mV
V _{OVLO}	OVLO Threshold	From V _{CC} Low to High		6		V
V _{OVLP_Hys}	OVLO Hysteresis			180		mV
V _{MSD}	Manual Shutdown Threshold Voltage	PROG Pin Rising PROG Pin Falling		1.2 1.0	1.3	V V
V _{ASD}	Vcc-VBAT Lockout Threshold Voltage	V _{CC} from low to High V _{CC} from High to Low	5	120 50		mV mV
ΔV _{RECHRG}	Auto Recharge Battery Voltage		100	150	200	mV
V _{CHRGb}	CHRGb Pin Output Low Voltage	I _{CHRGb} =5mA		0.2	0.6	V
T _{LIM}	Junction Temperature In CT Mode			165		°C
T _{SS}	Soft-Start Time	R _{PROG} =2kΩ		50		μs
T _{RECHRG}	Recharge Comparator Filter Time			2		ms
T _{TERM}	Termination Comparator Filter Time			1		ms
I _{PROG}	PROG Pin Pull-up Current		0.35	0.5	0.75	μA
V _{TEMP_EN}	Battery Temperature Detect Function Threshold Voltage	TEMP Pin Rising TEMP Pin Falling	0.18	0.29 0.2	0.32	V V
V _{TEMP_H}	TEMP Pin High Threshold Voltage	TEMP Pin Rising TEMP Pin Falling	72	80 73.5	82	%V _{CC} %V _{CC}
V _{TEMP_L}	TEMP Pin Low Threshold Voltage	TEMP Pin Rising TEMP Pin Falling	43	48.5 45	50	%V _{CC} %V _{CC}

Specifications subject to change without notice.



DIO5538B/C/D

5~100mA, Single Li-ion Battery Charger

Typical Performance Characteristics

VCC=5V, T_A= 25°C (unless otherwise noted)

PROG Pin Voltage vs. Ambient Temperature

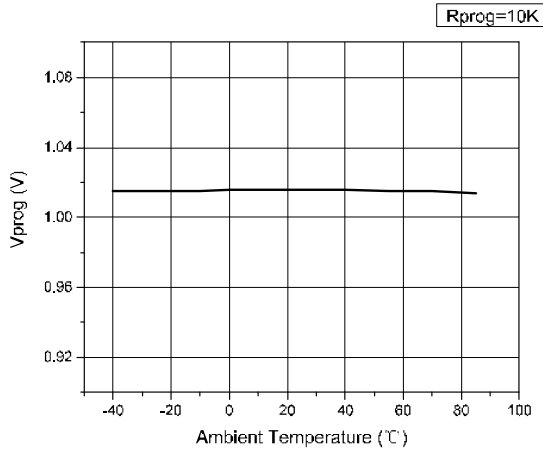

Float Voltage vs. Ambient Temperature (DIO5538B)

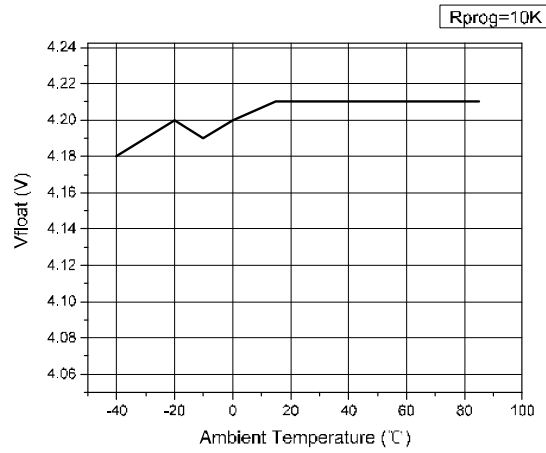

I_{charge} vs. Ambient Temperature

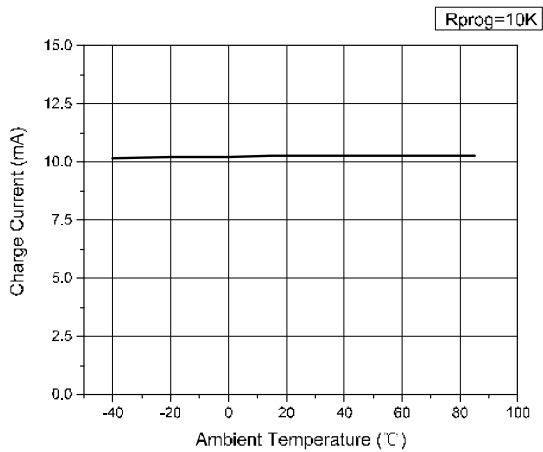

I_{trickle charge} vs. Ambient Temperature

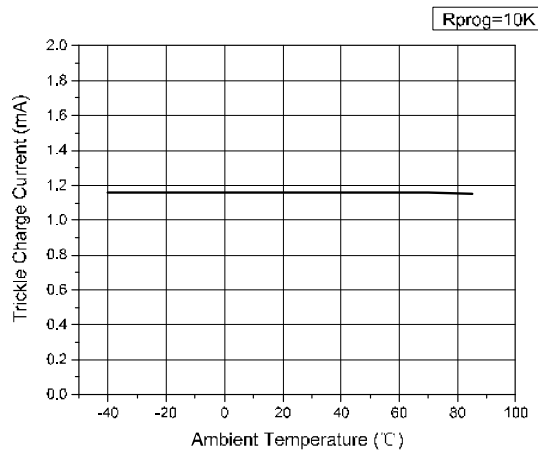

Charge Current vs. Battery Voltage

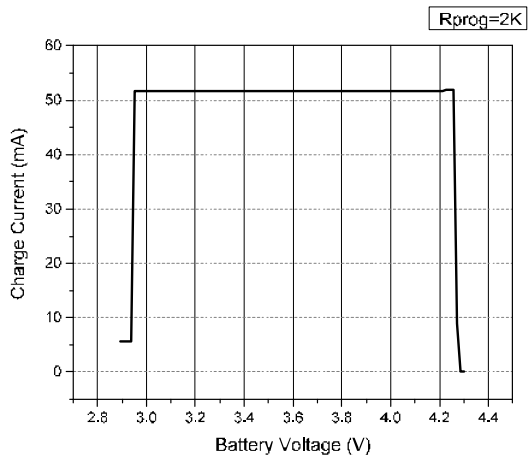

VCC Start-up

(VCC=5V, R_{PROG}=10kΩ, C_{BAT}=10μF, BAT connect to battery)

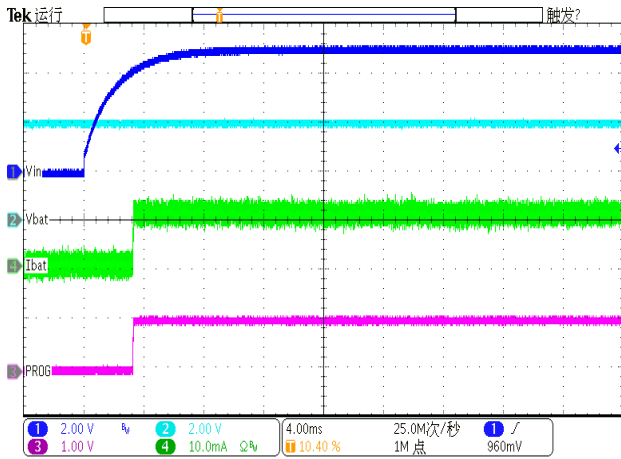

VCC Shut-down

(VCC=5V, R_{PROG}=10kΩ, C_{BAT}=10μF, BAT connect to battery)

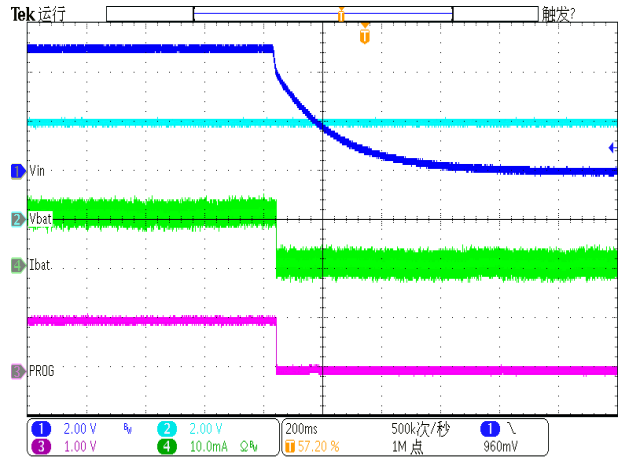

Charging Curve

(VCC=5V, R_{PROG}=10kΩ, C_{BAT}=10μF)

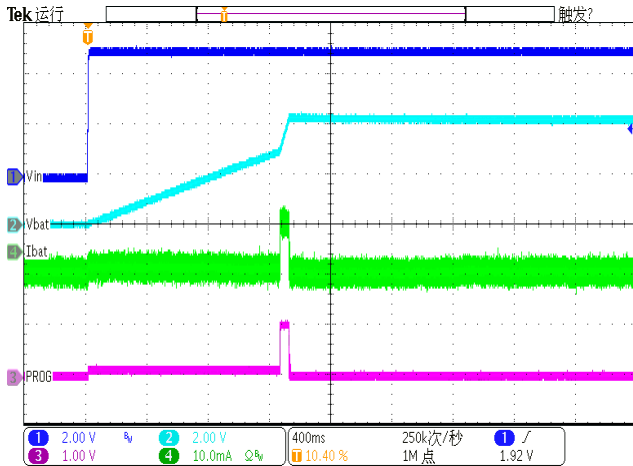

V_{BAT}

(VCC=5V, R_{PROG}=10kΩ, C_{BAT}=10μF)

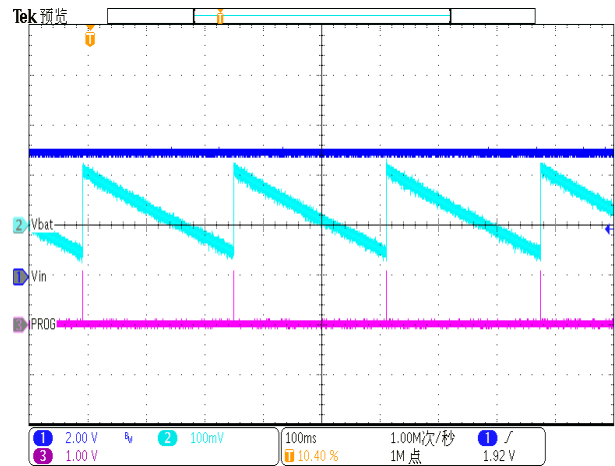

Block Diagram

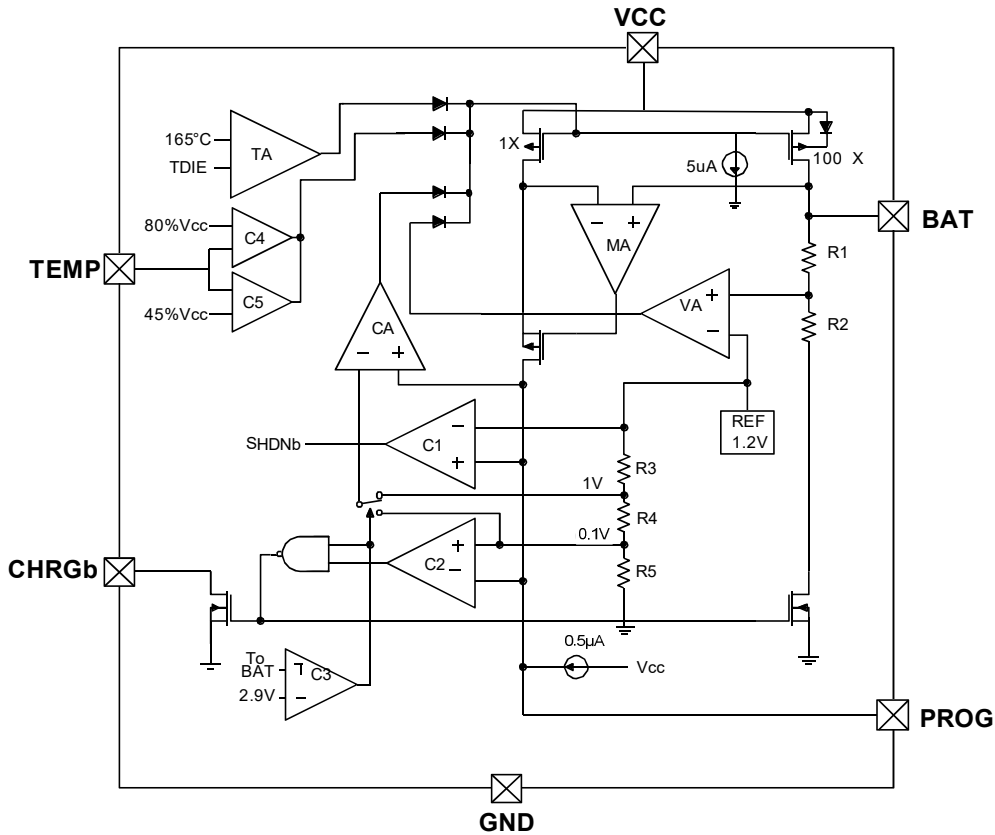

Figure 2. Function Block Diagram

Operation information

The DIO5538B/C/D is a single cell Lithium-Ion battery charger using a constant-current / constant-voltage algorithm. It can deliver up to 100mA of charge current with a final float voltage accuracy of $\pm 1\%$. The DIO5538B/C/D includes an internal P-channel power MOSFET and thermal regulation circuitry. No blocking diode or external current sense resistor is required; thus, the basic charger circuit requires only two external components. Furthermore, the DIO5538B/C/D is capable of operating from a USB power source.

Normal charge cycle

A charge cycle begins when the voltage at the VCC pin rises above the UVLO threshold level and a 1% program resistor is connected from the PROG pin to ground or when a battery is connected to the charger output. If the BAT pin is less than 2.9V, the charger enters trickle charge mode. In this mode, the DIO5538B/C/D supplies approximately 1/10 the programmed charge current to bring the battery voltage up to a safe level for full current charging.

When the BAT pin voltage rises above 2.9V, the charger enters constant-current mode, where the programmed charge current is supplied to the battery. When the BAT pin approaches the final float voltage, the DIO5538B/C/D enters constant-voltage mode and the charge current begins to decrease. The charge cycle ends when the PROG voltage is less than 100mV.

Programming charge current

The charge current is programmed using a single resistor from the PROG pin to ground. The battery charge current of constant current mode is 100 times the current out of the PROG pin. The program resistor and the charge current of constant current are calculated using the following equations:

$$I_{CHRG} = \left(\frac{1V}{R_{PROG}} \right) \times 100$$

Charge termination

A charge cycle is terminated when the charge current falls to 1/10 of the programmed value after the final float voltage is reached. This condition is detected by using an internal, filtered comparator to monitor the PROG pin. When the PROG pin voltage falls below 100mV for longer than T_{TERM} (typically 1ms), charging is terminated. The charge current is latched off and the DIO5538B/C/D enters standby mode, where the input supply current drops to 136 μ A. (Note: CC/10 termination is disabled in trickle charging mode and thermal limiting modes).

When charging, transient loads on the BAT pin can cause the PROG pin to fall below 100mV for short periods of time before the DC charge current has dropped to 1/10 of the programmed value. The 1ms filter time (T_{TERM}) on the termination comparator ensures that transient loads of this nature do not result in premature charge cycle termination. Once the average charge current drops below 1/10 of the programmed value, the DIO5538B/C/D terminates the charge cycle and ceases to provide any current through the BAT pin, the chip will be put into standby mode. In this state, all loads on the BAT pin must be supplied by the battery.

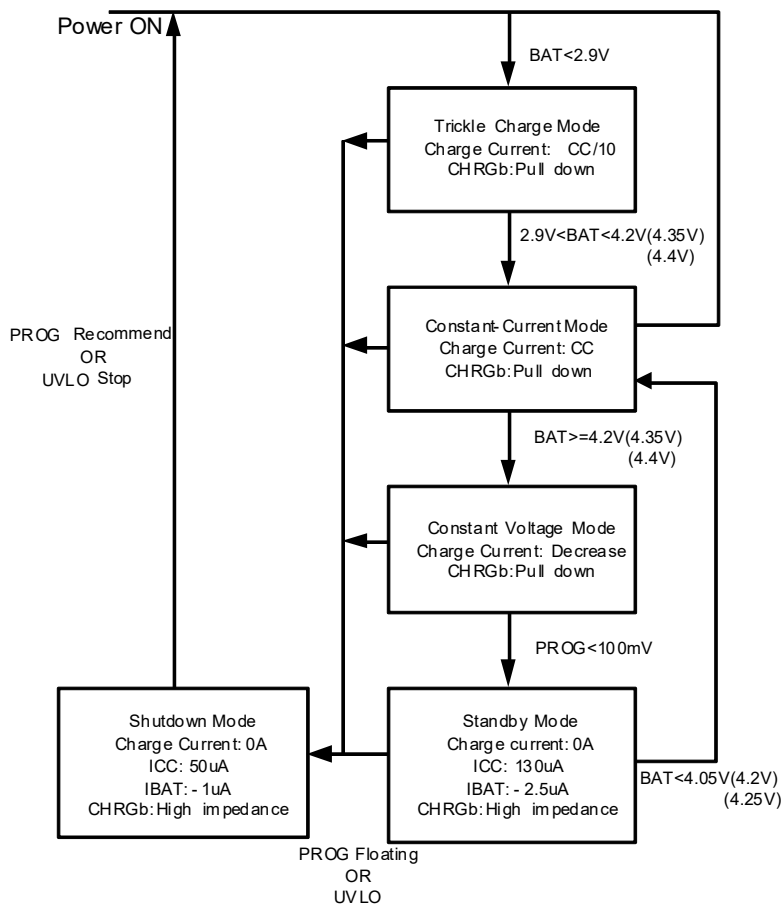

Figure 3. State Diagram of a Typical Charge Cycle



DIO5538B/C/D

The DIO5538B/C/D constantly monitors the BAT pin voltage in standby mode. If this voltage drops below the 4.05V/4.2V/4.25V recharge threshold (V_{RECHRG}), another charge cycle begins and current is once again supplied to the battery. The state diagram of a typical charge cycle is as Figure 3.

Charge status indicator

DIO5538B/C/D has an open-drain status indicator output CHRGb. CHRGb is pull-down when the DIO5538B/C/D in a charge cycle. In other status CHRGb is in high impedance. CHRGb is in high impedance when the battery out of the normal temperature.

Represent in failure state, when TEMP pin in typical connecting, and the charger with no battery: red LED don't light. The battery temperature sense function is disabled by connecting TEMP pin to GND. If battery is not connected to charger and the BAT pin connects a 10 μ F capacitor, the frequency of CHRGb flickers is about 1-4s.

Charger state	Red GHRGb
Charging	light
Battery in full state	dark
UVLO, Battery temperature is outside TEMP range, battery is note connected (Use TEMP)	dark
BAT pin is connected to 10 μ F and no battery mode (TEMP=GND)	Red LED flicker and the frequency is 1~4s

Thermal Limiting

An internal thermal feedback loop reduces the programmed charge current if the die temperature attempts to rise above a preset value of approximately 165°C. This feature protects the DIO5538B/C/D from excessive temperature and allows the user to push the limits of the power handling capability of a given circuit board without risk of damaging the DIO5538B/C/D. The charge current can be set according to typical (not worst-case) ambient temperature with the assurance that the charger will automatically reduce the current in worst-case conditions.

Battery Temperature Sensing

To prevent the damage caused by the very high or very low temperature done to the battery pack, the DIO5538B/C/D continuously senses the battery pack temperature by measuring the voltage at TEMP pin determined by the voltage divider circuit and the battery's internal NTC thermistor.

The DIO5538B/C/D compares the voltage at TEMP pin (V_{TEMP}) against its internal V_{LOW} and V_{HIGH} thresholds to determine if charging is allowed. In DIO5538B/C/D, V_{LOW} is fixed at 45% $\times V_{CC}$, while V_{HIGH} is fixed at 80% $\times V_{CC}$. If $V_{TEMP} < V_{LOW}$ or $V_{TEMP} > V_{HIGH}$, it indicates that the battery temperature is too high or too low and the charge cycle is suspended. When the V_{TEMP} is between V_{LOW} and V_{HIGH} , charging cycle resumes. The battery temperature sensing function can be disabled by connecting the TEMP pin to GND.

Selecting R1 and R2

The values of R1 and R2 in the application circuit (Figure1) can be determined according to the assumed temperature monitor range and thermistor's values. The Follows is an example: Assume temperature monitor range is $T_L \sim T_H$, ($T_L < T_H$); the thermistor in battery has negative temperature coefficient (NTC), R_{TL} is thermistor's resistance at T_L , R_{TH} is the resistance at T_H , so $R_{TL} > R_{TH}$, then

At temperature T_L , the volatge at TEMP pin is:

$$V_{TEMP_L} = \frac{R_2 // R_{TL}}{R_1 + R_2 // R_{TL}} \times V_{CC}$$

At temperature T_H , the volatge at TEMP pin is:

$$V_{TEMP_H} = \frac{R_2 // R_{TH}}{R_1 + R_2 // R_{TH}} \times V_{CC}$$

Because $V_{TEMP_L} = V_{HIGH} = K_2 \times V_{CC}$ ($K_2 = 0.8$)

$$V_{TEMP_H} = V_{LOW} = K_1 \times V_{CC} \quad (K_1 = 0.45)$$

Then we can have:

$$R_1 = \frac{R_{TL} \times R_{TH} (K_2 - K_1)}{(R_{TL} - R_{TH}) K_1 \times K_2}$$

$$R_2 = \frac{R_{TL} \times R_{TH} (K_2 - K_1)}{R_{TL} (K_1 - K_1 \times K_2) - R_{TH} (K_2 - K_1 \times K_2)}$$

Likewise, for positive temperature coefficient thermistor in battery, we have $R_{TH} > R_{TL}$ and we can calculate:

$$R_1 = \frac{R_{TH} \times R_{TL} (K_2 - K_1)}{(R_{TH} - R_{TL}) K_1 \times K_2}$$

$$R_2 = \frac{R_{TH} \times R_{TL} (K_2 - K_1)}{R_{TH} (K_1 - K_1 \times K_2) - R_{TL} (K_2 - K_1 \times K_2)}$$

We can conclude that temperature monitor range is independent of power supply voltage V_{CC} and it only depends on R1, R2, R_{TL} and R_{TH} : The values of R_{TH} and R_{TL} can be found in ralated battery handbook or deduced from testing data. In actual application, if only one terminal temperature is concerned (normally protecting overheating), there is no ennd to use R2 but R1. It becomes very simple to calculate R1 in this case.

Undervoltage Lockout (UVLO)

An internal undervoltage lockout circuit monitors the input voltage and keeps the charger in shutdown mode until V_{CC} rises above the undervoltage lockout threshold. The UVLO circuit has a built-in hysteresis of 250mV. Furthermore, to protect against reverse current in the power MOSFET, the UVLO circuit keeps the charger in

shutdown mode if V_{CC} falls to within 50mV of the battery voltage. If the UVLO comparator is tripped, the charger will not come out of shutdown mode until V_{CC} rises 120mV above the battery voltage.

Overvoltage Lockout (OVLO)

An internal overvoltage lockout circuit monitors the input voltage and keeps the charger in shutdown mode until V_{CC} fall down the overvoltage lockout threshold. The OVLO circuit has a built-in hysteresis of 180mV. Furthermore, to protect against reverse current in the power MOSFET, the OVLO circuit keeps the charger in shutdown mode if V_{CC} falls to within 50mV of the battery voltage. If the OVLO comparator is tripped, the charger will not come out of shutdown mode until V_{CC} rises 120mV above the battery voltage.

Manual Shutdown

At any point in the charge cycle, the DIO5538B/C/D can be put into shutdown mode by removing R_{PROG} thus floating the PROG pin. This reduces the battery drain current to less than $1\mu A$ and the supply current to less than $50\mu A$. A new charge cycle can be initiated by reconnecting the program resistor.

In manual shutdown, The $CHRGb$ pin is in a high impedance state if the DIO5538B/C/D is in manual shutdown mode or in the undervoltage lockout mode: either V_{CC} is within 120mV of the BAT pin voltage or insufficient voltage is applied to the V_{CC} pin.

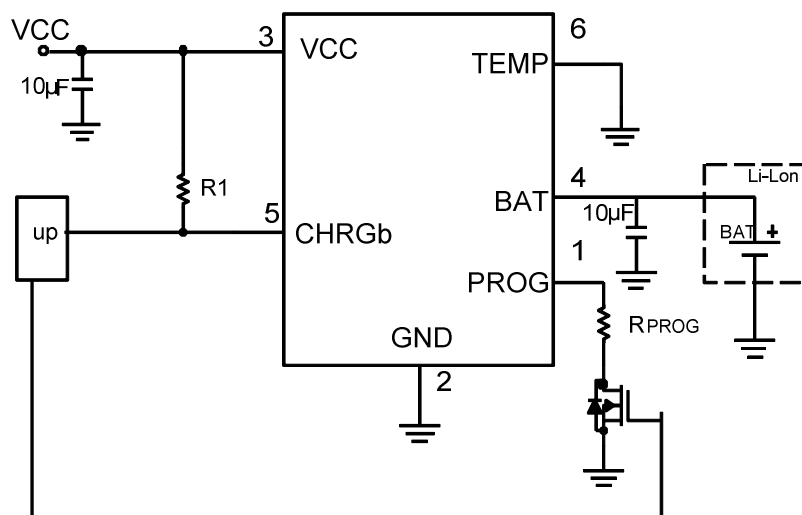

Figure 4. Manual Shutdown Mode Application Circuit

Automatic recharge

Once the charge cycle is terminated, the DIO5538B/C/D continuously monitors the voltage on the BAT pin using a comparator with a 2ms filter time (T_{RECHRG}). A charge cycle restarts when the battery voltage falls below $4.05V/4.2V/4.25V$ (Typ.) (which corresponds to approximately 80% to 90% battery capacity). This ensures that the battery is kept at or near a fully charged condition and eliminates the need for periodic charge cycle initiations. $CHRGb$ output enters a pull-down state during recharge cycles.

Application Information

Typical Application

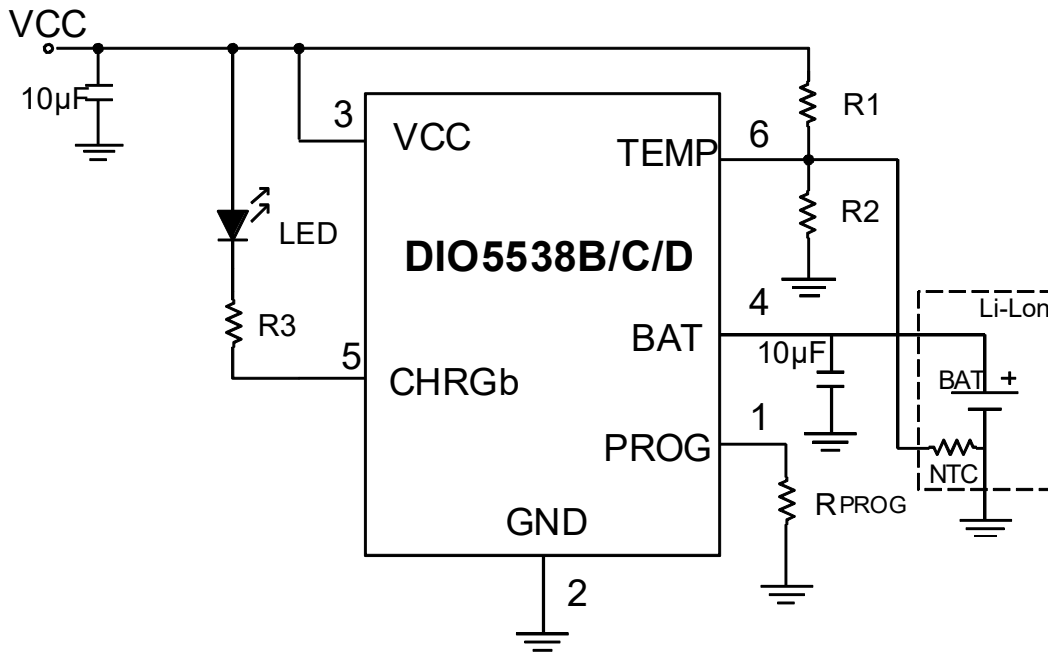

Figure 5. Typical applications W/T LED indicate

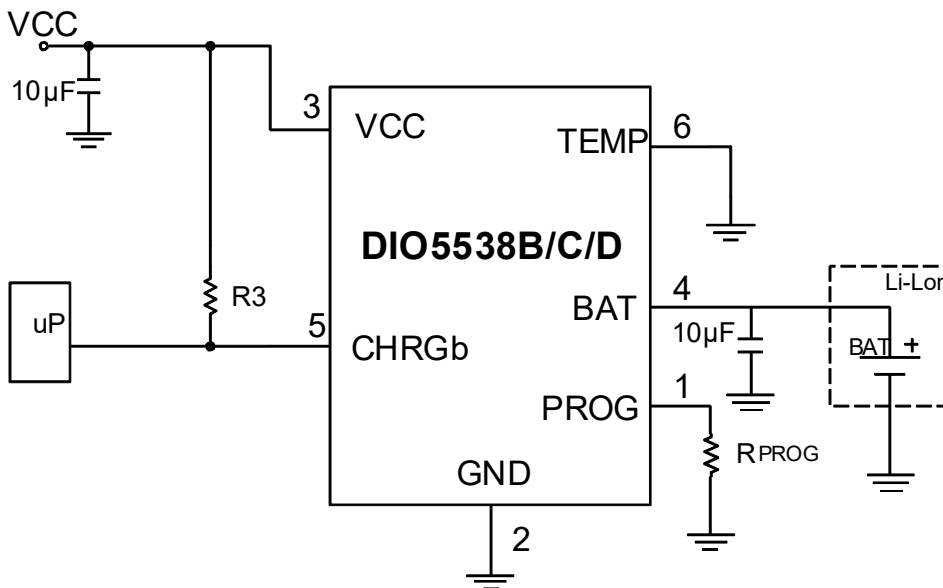

Figure 6. Typical applications W/T microprocessor detect

Stability considerations

The constant-voltage mode feedback loop is stable without an output capacitor provided a battery is connected to the charger output. With no battery present, an output capacitor is recommended to reduce ripple voltage. When using high value, low ESR ceramic capacitors, it is recommended to add a 1Ω resistor in series with the capacitor. No series resistor is needed if tantalum capacitors are used.



DIO5538B/C/D

In constant-current mode, the PROG pin is in the feedback loop, not the battery. The constant-current mode stability is affected by the impedance at the PROG pin. With no additional capacitance on the PROG pin, the charger is stable with program resistor values as high as 50KΩ. However, additional capacitance on this node reduces the maximum allowed program resistor thus it should be avoided.

Thermal Limit

An internal thermal feedback loop reduces the programmed charge current if the die temperature attempts to rise above a preset value of approximately 165°C. This feature protects the DIO5538B/C/D from excessive temperature and allows the user to push the limits of the power handling capability of a given circuit board without risk of damaging the DIO5538B/C/D. The charge current can be set according to typical (not worst-case) ambient temperature with the assurance that the charger will automatically reduce the current in worst-case conditions.

Power dissipation

The conditions that cause the DIO5538B/C/D to reduce charge current through thermal feed-back can be approximated by considering the power dissipated in the IC. Nearly all of this power dissipation is generated by the internal MOSFET. This is calculated to be approximately:

$$P_D = (V_{CC} - V_{BAT}) \times I_{BAT}$$

It is important to remember that DIO5538B/C/D applications do not be designed for worst-case thermal conditions since the IC will automatically reduce power dissipation when the junction temperature reaches approximately 165°C (Constant temperature mode).

VCC bypass capacitor

Many types of capacitors can be used for input bypass, however, caution must be exercised when using multilayer ceramic capacitors. Because of the self-resonant and high Q characteristics of some types of ceramic capacitors, a 10μF ceramic capacitor is recommended for this bypass capacitor. Due to a high voltage transient will be generated under some start-up conditions, such as connecting the charger input to a live power source.

Charge current soft-start

The DIO5538B/C/D includes a soft-start circuit to minimize the inrush current at the start of a charge cycle. When a charge cycle is initiated, the charge current ramps from zero to the full-scale current over a period of approximately 100μs. This has the effect of minimizing the transient current load on the power supply during start-up.



DIO5538B/C/D

5~100mA, Single Li-ion Battery Charger

CONTACT US

Dioo is a professional design and sales corporation for high-quality and performance analog semiconductors. The company focuses on industry markets, such as, cell phone, handheld products, laptop, and medical equipment and so on. Dioo's product families include analog signal processing and amplifying, LED drivers and charger IC. Go to <http://www.dioo.com> for a complete list of Dioo product families.

For additional product information, or full datasheet, please contact with our Sales Department or Representatives.